

INTERFERENCE REJECTION

IF NOTCH FILTER OPERATION (SSB/CW/RTTY/DATA/AM MODES)

The IF NOTCH filter is a highly effective system that allows you to slice out an interfering beat note or other carrier signal from inside the receiver passband.

1. Press the **F(M-LIST)** button, then touch **[NOTCH]** on the LCD to activate the Notch filter. The DSP graphic display will illuminate and the current “null” position of the NOTCH filter will appear in the NOTCH indicator on the display. The **MULTI** knob functions as the Notch adjustment knob.
2. Rotate the **MULTI** knob to adjust the “null” position of the Notch filter.
3. To cancel the NOTCH filter, touch **[NOTCH]** on the LCD. The graphic disappears from the NOTCH indicator on the display, confirming that the NOTCH filter is no longer in operation.

ADVICE:

Alternate touches of **[NOTCH]**, will switch the NOTCH filter between on and off.

ADVICE:

- The bandwidth of the NOTCH filter (either narrow or wide) may be adjusted using Menu item “114 IF NOTCH WIDTH”. The factory default setting is “WIDE”.

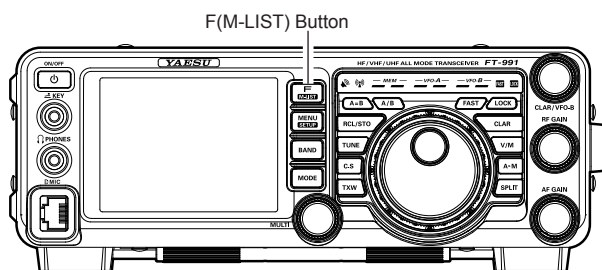

The performance of the IF NOTCH filter is illustrated in Figure “A”, where the effect of rotation of the **MULTI** knob is depicted. In Figure “B” you can see the notching effect of the IF NOTCH filter as you rotate the **MULTI** knob to eliminate the interfering heterodyne.

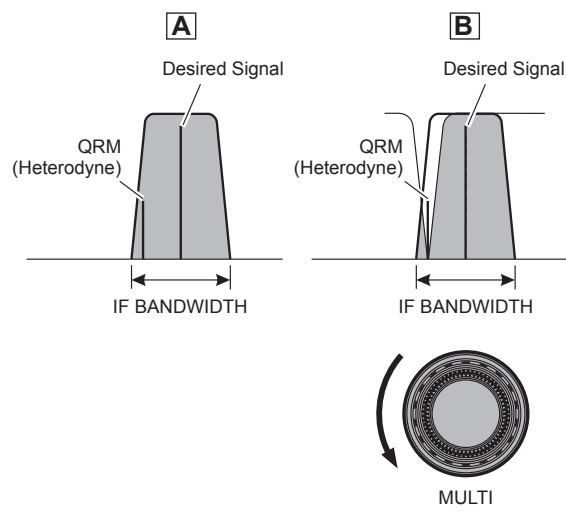

DIGITAL NOTCH FILTER (DNF) OPERATION

The Digital NOTCH Filter (DNF) is an effective beat-canceling filter that can null out a number of interfering beat notes inside the receiver passband. Because this is an Auto-Notch feature, there is no adjustment knob associated with this filter.

ADVICE:

If a very strong interfering carrier is encountered, we recommend you first use the IF NOTCH filter, as it is the most effective notching tool in the receiver section.

1. Press the **F(M-LIST)** button, then touch **[DNF]** on the LCD. The “**DNF**” will appear in the display.

To disable the Digital NOTCH Filter, just repeat the above procedure, touching **[DNF]** on the LCD to choose “OFF”. The “**DNF**” will turn off, confirming that the Digital NOTCH Filter is not active.

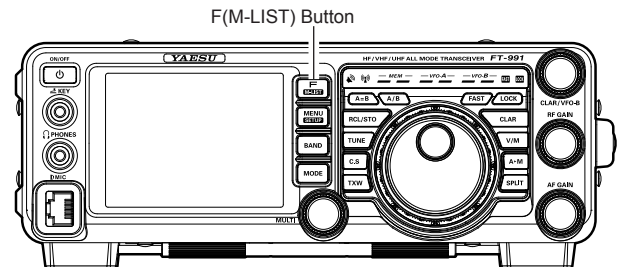

DIGITAL NOISE REDUCTION (DNR) OPERATION

The Digital Noise Reduction (DNR) system is designed to reduce the level of random noise found on the HF and 50 MHz bands, and it is especially effective during SSB operation. By setting the Menu item “110 DNR LEVEL”, any of 15 different noise-reduction algorithms can be selected; each of these algorithms was created for dealing with a different noise profile. You will want to experiment with the DNR system to find the best setting corresponding to the noise currently being experienced.

1. Press the **F(M-LIST)** button, then touch **[DNR]** on the LCD. The “**DNR**” will appear in the display.

To disable the DNR system, just repeat the above procedure, touching **[DNR]** on the LCD to choose “OFF”. The “**DNR**” will turn off, confirming that the DNR system is not active.

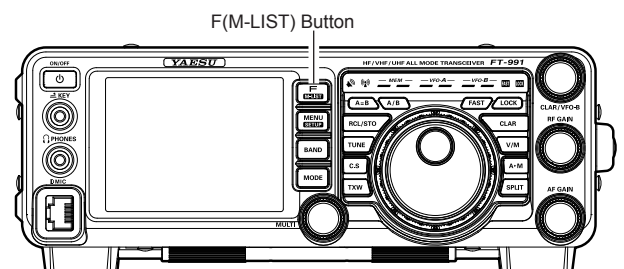

RF GAIN

The RF Gain control provides manual adjustment of the gain levels for the receiver RF and IF stages, to account for noise and signal strength conditions at the moment.

1. The **RF GAIN** knob should, initially, be rotated to the fully clockwise position. This is the point of maximum sensitivity.
2. Counter-clockwise rotation of the **RF GAIN** knob will gradually reduce the system gain.

ADVICE:

- As the **RF GAIN** knob is rotated counterclockwise to reduce the gain, the S-meter reading will rise. This indicates that the AGC voltage being applied to the receiver is increasing (this causes a *reduction* in receiver gain).
- Rotating the **RF GAIN** knob control to the fully counter-clockwise position will essentially disable the receiver, as the gain will be greatly reduced. In this case, the S-meter will appear to be “pegged” against the right edge of the analog S-meter scale.

QUICK POINT:

- Reception frequently can be optimized by rotating the **RF GAIN** knob slightly counter-clockwise to the point where the “stationary” meter indication is set just about the same as the incoming noise level. This will reduce the RF gain to find a level of improved signal to noise ratio.
- The RF Gain control, along with the IPO and the Attenuator features, all affect the system receiver gain in different ways. The IPO generally should be the first feature engaged when dealing with a high noise level, or a crowded, high-level signal environment. Also, the IPO generally should be the first feature engaged, if the frequency is low enough to allow the preamplifier to be bypassed. Thereafter, the RF Gain and Attenuator features may be employed to provide precise, delicate adjustment of the receiver gain to fully optimize performance.

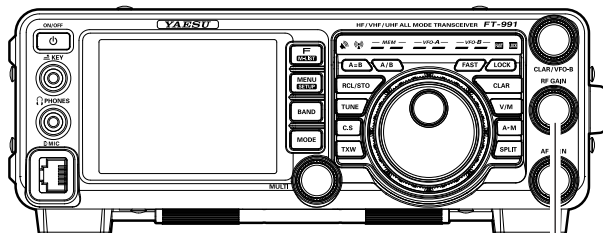

RF GAIN Knob

AUDIO PEAK FILTER

1. Press the **F(M-LIST)** button, then touch [**APF**] on the LCD. The “**APF**” indicator will appear in the DSP display.

ADVICE:

When APF is engaged, the peak position of the APF is depicted graphically in the NOTCH indicator on the display.

2. Touch [**APF**] on the LCD again to disable the APF.

ADVICE:

The APF may only be activated while the transceiver is in CW mode.

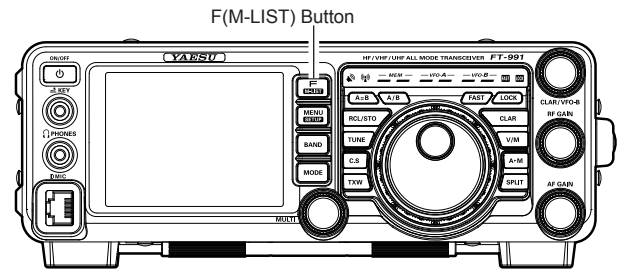

AGC (AUTOMATIC GAIN CONTROL)

The AGC system is designed to help compensate for fading and other propagation effects. The AGC characteristics can be individually set for each operating mode. The basic objective of AGC is to maintain a constant audio output level once a certain minimum threshold of signal strength is achieved.

Press the **F(M-LIST)** button, then touch **[AGC]** on the LCD repeatedly to select the desired receiver-recovery time constant. You will observe the AGC status notation in the AGC column of the Key Function Display on the TFT display, denoting the AGC receiver-recovery time currently in use. For most operations, we recommend the “AUTO” mode. Additionally, you may disable the AGC by touching **[AGC]** on the LCD.

NOTE:

- The “AUTO” selection mode selects the optimum receiver-recovery time for the reception mode. In this case, the selected receiver-recovery time in the AGC column of the Key Function Display glows green (Normally glows blue).
- Touching **[AGC]** on the LCD allows selection of the desired receiver-recovery time constant. Normally, the “AUTO” selection is satisfactory for most situations, but in the event of operation on a crowded band where you wish to receive a weak signal, you may wish to change the setting to FAST. The AUTO mode selections are:

OPERATING MODE	AUTO AGC SELECTION
LSB/USB/AM	SLOW
CW/FM	FAST
RTTY/DATA	MID

F(M-LIST) Button

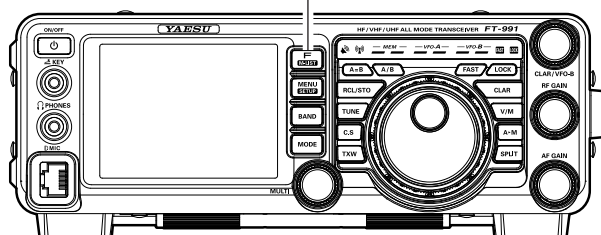

ADVICE:

- If the AGC receiver-recovery time is set to “Off” by touching **[AGC]** on the LCD, the S-meter will no longer deflect. Additionally, you will likely encounter distortion on stronger signals, as the IF amplifiers and the following stages are probably being overloaded.

QUICK POINT:

Several aspects of AGC performance may be configured via the Menu. However, because AGC can have such a profound impact on overall receiver performance, we generally do not recommend any changes to the AGC Menu selections until you are thoroughly familiar with the performance of the **FT-991**.

TERMINOLOGY:

Automatic Gain Control, or AGC, is a circuit that senses the received signal strength, and then limits the gain of the RF and IF stages to keep the output audio volume at a more-or-less constant level. AGC also protects the RF, IF, Audio, and DSP stages from overload, as it limits the signal strength that is allowed to flow, irrespective of the input signal level.

TOOLS FOR COMFORTABLE AND EFFECTIVE RECEPTION

ADJUSTABLE RECEIVER AUDIO FILTER

The **FT-991** includes an adjustable receiver audio filter, that provides precise, independent control of the low; and upper audio ranges.

1. Press the **MENU** button to enter the Menu mode.
2. Rotate the **MULTI** knob to find Menu items “040” through “043” these parameters apply to the adjustment of the receiver audio filter in the AM mode, Menu items “050” through “053” apply to the adjustment of the RX audio filter in the CW mode, Menu items “067” through “070” apply to the adjustment of the RX audio filter in the DATA mode, Menu items “092” through “095” apply to the adjustment of the RX audio filter in the RTTY mode, and Menu items “102” through “105” apply to the adjustment of the RX audio filter in the SSB mode
3. Touch [**SELECT**] on the LCD.
4. Rotate the **MULTI** knob to adjust the receiver audio response as desired.
5. Touch [**ENTER**] on the LCD to save the new setting.
6. Press the **MENU** button or touch [**BACK**] on the LCD to exit to normal operation.

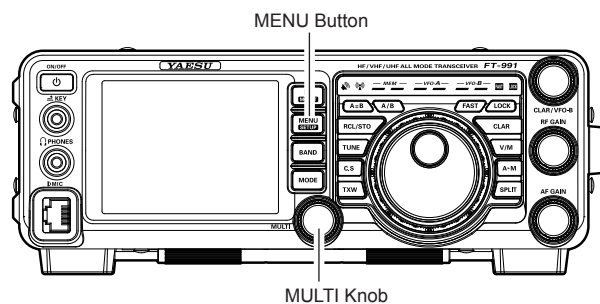

MODE	MENU ITEM	AVAILABLE VALUES
AM	040 AM LCUT FREQ	OFF/100(Hz) ~ 1000(Hz)
	041 AM LCUT SLOPE	6dB/oct / 18dB/oct
	042 AM HCUT FREQ	700(Hz) ~ 4000(Hz)/OFF
	043 AM HCUT SLOPE	6dB/oct / 18dB/oct
CW	050 CW LCUT FREQ	OFF/100(Hz) ~ 1000(Hz)
	051 CW LCUT SLOPE	6dB/oct / 18dB/oct
	052 CW HCUT FREQ	700(Hz) ~ 4000(Hz)/OFF
	053 CW HCUT SLOPE	6dB/oct / 18dB/oct
DATA	067 DATA LCUT FREQ	OFF/100(Hz) ~ 1000(Hz)
	068 DATA LCUT SLOPE	6dB/oct / 18dB/oct
	069 DATA HCUT FREQ	700(Hz) ~ 4000(Hz)/OFF
	070 DATA HCUT SLOPE	6dB/oct / 18dB/oct
RTTY	092 RTTY LCUT FREQ	OFF/100(Hz) ~ 1000(Hz)
	093 RTTY LCUT SLOPE	6dB/oct / 18dB/oct
	094 RTTY HCUT FREQ	700(Hz) ~ 4000(Hz)/OFF
SSB	095 RTTY HCUT SLOPE	6dB/oct / 18dB/oct
	102 SSB LCUT FREQ	OFF/100(Hz) ~ 1000(Hz)
	103 SSB LCUT SLOPE	6dB/oct / 18dB/oct
	104 SSB HCUT FREQ	700(Hz) ~ 4000(Hz)/OFF
	105 SSB HCUT SLOPE	6dB/oct / 18dB/oct

SSB/AM MODE TRANSMISSION

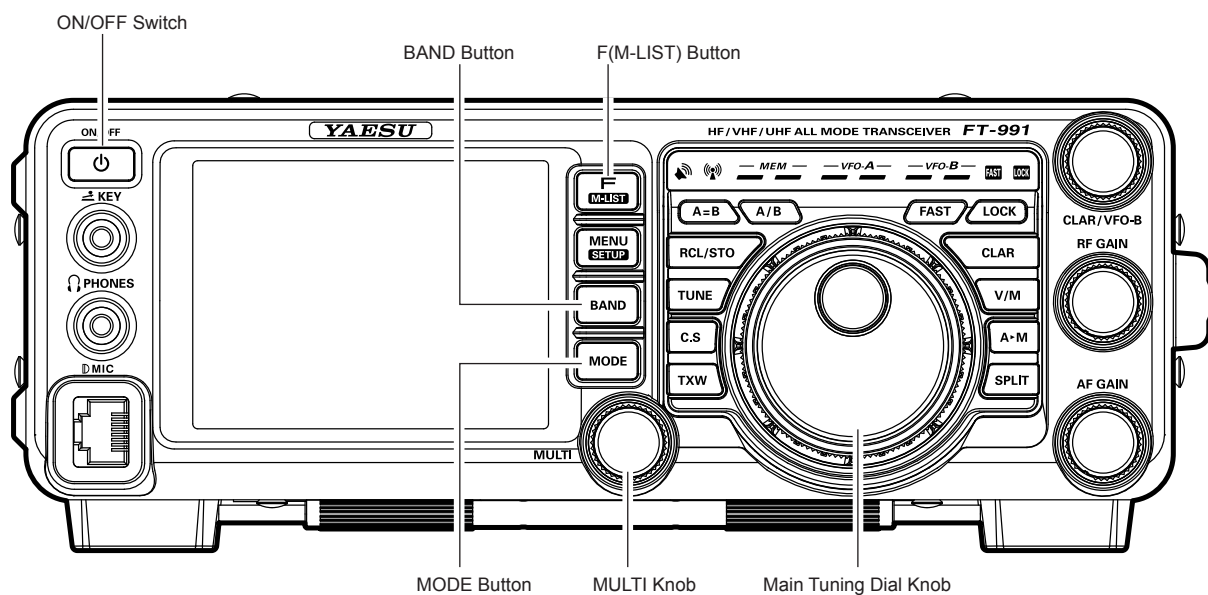

1. Press the **BAND** button to show the band list, then touch a band key corresponding to the Amateur band on which you wish to operate.
2. Press the **MODE** button to show the mode list, then select the operating mode by touching the corresponding key.

ADVICE:

By convention, LSB is used in the 7 MHz and lower Amateur bands for SSB communication, and USB is used on the 14 MHz and higher bands (the 10 MHz band is used for CW and data modes only).

3. Rotate the Main Tuning Dial knob to adjust the operating frequency. Alternately, you may use the **UP/DWN** scanning buttons on the **MH-31A8J** Hand Microphone to sweep up or down the current band.
4. Press the microphone **PTT** (Push To Talk) switch to begin transmission; speak into the microphone in a normal voice level.

ADVICE:

- ❑ The “” indicator will light up in the LED indicators area, confirming that transmission is in progress.
- ❑ When transmitting in the AM mode, set a maximum (carrier) power output of 25 Watts via **[PROC]** displayed by pressing the **F(M-LIST)** button.

5. Adjust the microphone amplifier gain to match the microphone and your voice level: Touch **[METER]** on the LCD repeatedly to select the “ALC”. Press and hold the **PTT** switch, and speak into the microphone in a normal voice level.
In the SSB mode, touch **[MIC GAIN]** and then adjust **MULTI** knob so that the ALC meter stays within the ALC zone of the meter (up to half scale deflection) on voice peaks.
In the AM mode, touch **[MIC GAIN]** and then adjust **MULTI** knob so that the ALC meter does not deflect at voice peaks.
6. Release the **PTT** switch at the end of your transmission. The transceiver will return to the receive mode.

SSB/AM MODE TRANSMISSION

ADVICE:

- ❑ ALC meter deflection may be caused by excessive drive power, but also by reflected power detected in the antenna system. If the impedance presented to the transceiver is other than 50 Ohms, ALC meter action may be observed that is not related to the proper setting of [MIC GAIN] on the LCD. Therefore, we recommend that you make [MIC GAIN] adjustments into a dummy load or antenna system presenting impedance very close to 50 Ohms.
- ❑ When performing “on air” tests (such as the setup of microphone gain), be sure to check the frequency before transmitting, to avoid interference to others who may already be using the frequency.
- ❑ Four techniques for exercising Transmit/Receive control are provided on the **FT-991**. You may choose the technique(s) that best suit your operating needs:
 - Pressing the microphone **PTT** switch will engage the transmitter.
 - The rear panel **PTT** jack may be connected to a foot switch or other manual switching device in order to engage the transmitter.
 - Touching [MOX] displayed by pressing the **F(M-LIST)** button will lock the transmitter on. Touch [MOX] on the LCD again to return to receive.
 - The VOX (Voice Operated Xmit) circuit will engage the transmitter automatically when you speak into the microphone. For details of VOX operation refer to page ##.

USING THE AUTOMATIC ANTENNA TUNER

The Automatic Antenna Tuner (hereinafter referred to as the “ATU”) built into each **FT-991** is designed to ensure a 50-Ohm load for the final amplifier stage of the transmitter. We recommend that the ATU be used whenever you operate on the **FT-991**.

ADVICE:

- ❑ Because the ATU of the **FT-991** is located inside the station, it only adjusts the impedance presented to the transceiver at the station end of your coaxial cable feedline. It does not “tune” the SWR at the antenna feed point itself. When designing and building your antenna system, we recommend that every effort be made to ensure a low SWR at the antenna feed point.
- ❑ The ATU of the **FT-991** includes 100 memories for tuning data. Eleven of these memories are allocated, one per Amateur band, so that each band has at least one setting preset for use on that band. The remaining 89 memories are reserved for the 89 most-recent tuning points, for quick frequency change without the need to retune the ATU.
- ❑ The ATU in the **FT-991** is designed to match impedances within the range of 16.5 Ohms to 150 Ohms, corresponding to an SWR of 3:1 or less on the 160 through 6 meter amateur bands. Accordingly, simple non-resonant whip antennas, along with random-length wires and the “G5RV” antenna (on most bands) may not be within the impedance matching range of the ATU.

ATU OPERATION

1. Use the Main Tuning Dial knob to set the radio to the desired operating frequency within the Amateur band.
2. Press the **TUNE** button momentarily to place the ATU in the transmit line (no adjustment/tuning will occur yet). The “**TUNER**” icon will appear in the display.

QUICK POINT:

The momentary press of the **TUNE** button will turn the tuner on, and the microprocessor will automatically select the tuning point closest to the current operating frequency.

3. Press and hold in the **TUNE** button for one second to begin automatic tuning. The transmitter will be engaged, and the “**TUNER**” icon will blink while tuning is in progress. When the optimum tuning point has been reached, the radio will return to receive, and the “**TUNER**” icon will again glow steadily (instead of blinking).
4. To disconnect the ATU from the transmit line, press the **TUNE** button momentarily. The “**TUNER**” icon will turn off, confirming that the ATU has been turned off. In the “Off” mode, the transceiver will be directly connected to the coaxial cable connected to your antenna, and will respond to whatever impedance is present at the station end of the coax.

ADVICE:

The ATU circuit is located between the final amplifier and the rear-panel antenna jack; reception is not affected by the ATU.

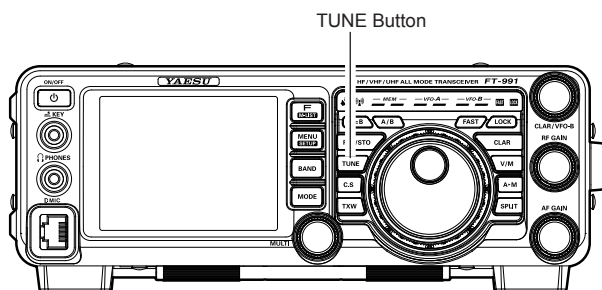

QUICK POINTS:

As shipped from the factory, only one ATU alignment point is saved on each Amateur band. This was memorized during the final alignment and performance verification stages on the production line.

NOTE:

Please check the operating frequency before beginning the tuning process, to be sure you are not interfering with others who may already be using the frequency.

TERMINOLOGY:

Antenna Tuner Memories: The microprocessor of the ATU makes a note of the selected tuning capacitors and inductors, and stores the data for each 10 kHz window in which tuning has occurred. This eliminates the need to re-tune every time you return to a frequency on which you have already completed the tuning process.

USING THE AUTOMATIC ANTENNA TUNER

ABOUT ATU OPERATION

Figure 1 depicts a situation where normal tuning via the ATU has been successfully completed, and the tuning data has been stored in the ATU memory. The antenna system as seen by the transmitter is shown.

In Figure 2, the operator has changed frequency, and the “**HI-SWR**” icon has appeared. The operator presses and holds in the **TUNE** button for two seconds to begin impedance matching using the ATU.

If a high SWR condition exists (above 3:1), corrective action must be taken in the antenna system to bring the impedance closer to 50 Ohms. The ATU will refuse to memorize settings on frequencies where the SWR exceeds 3:1. A High SWR may indicate a mechanical failure in the feed system, and can lead to the generation of spurious signals causing TVI, etc.

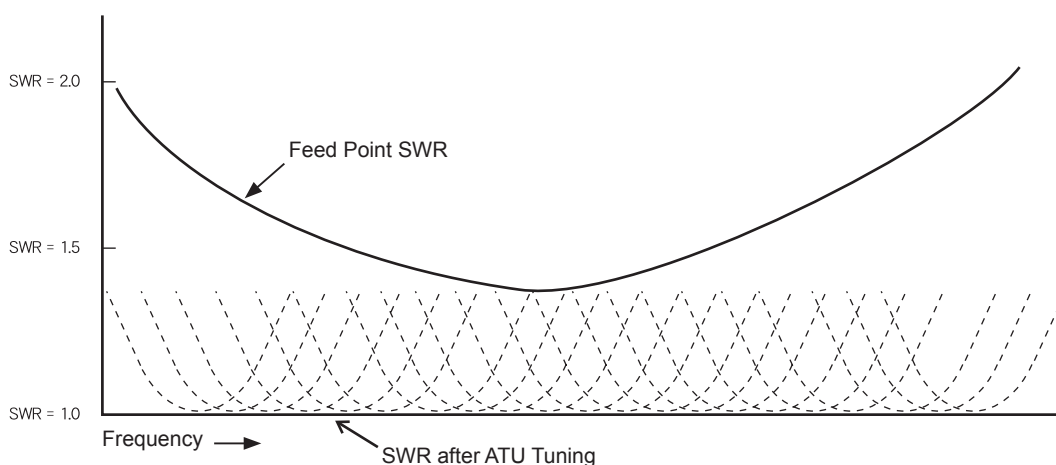

FIGURE 1

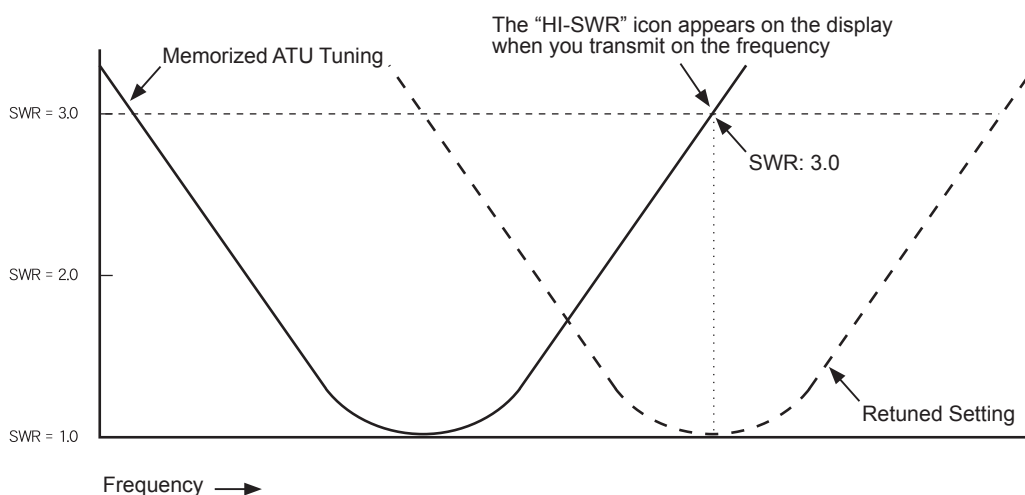

FIGURE 2

About ATU Memories

SWR (After tuning) Less than 1.5:1

The tuner settings are stored in the ATU memory.

SWR (After tuning) Greater than 1.5:1

Tuning data will not be retained in memory. If you return to the same frequency, the tuning process must be repeated.

SWR (After tuning) Greater than 3:1

The “**HI-SWR**” icon will light up, and the tuner settings, if achieved, will not be memorized. Please investigate the high SWR condition and resolve the problem before attempting further operation using this antenna.

ENHANCING TRANSMIT SIGNAL QUALITY

PARAMETRIC MICROPHONE EQUALIZER (SSB/AM/FM MODE)

The **FT-991** includes a unique Three-Band Parametric Microphone Equalizer that provides precise, independent control over the low, mid and treble ranges in your voice waveform. You may utilize one group of settings when the speech processor is off and an alternate group of settings when the speech processor is on. The speech processor feature is described in the next chapter.

QUICK POINT:

The Parametric Equalizer is a unique technique for adjusting the signal quality. The three audio ranges may be adjusted so precisely, it is possible to craft an audio response that provides a natural and pleasant sound that you may not have ever experienced before. Alternately, the effective “talk power” can be significantly enhanced.

The aspects of configuration that you may adjust on the Parametric Equalizer are:

Center Frequency: The center frequency of each of the three bands may be adjusted.

Gain: The amount of enhancement (or suppression) within each band may be adjusted.

Q: The bandwidth over which the equalization is applied may be adjusted.

Setup of the Parametric Microphone Equalizer

1. Connect the microphone to the **MIC** jack.
2. Set the RF output power to minimum value.

ADVICE:

- We recommend that you connect a dummy load to one of the Antenna jacks, and monitor your signal on a separate receiver, to prevent interference to other users.
 - You will have the best chance of hearing the effects of adjustments if you wear headphones (connected to the monitor receiver) while listening to your transmitted signal.
3. To adjust the Parametric Microphone Equalizer while the speech processor is disabled, press the **F(M-LIST)** button, then touch **[MIC-EQ]** to select “ON”.
To adjust the Parametric Microphone Equalizer with the speech processor engaged, press the **F(M-LIST)** button, then touch **[PROC]** to select “ON”.

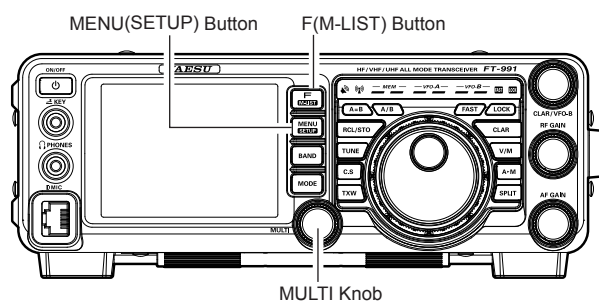

4. Touch **[MONI]**, if you want to listen on the **FT-991** internal monitor.
5. Press the **MENU(SETUP)** button. The Menu list will appear in the display.
6. Rotate the **MULT** knob to find the “EQ” Menu area, containing Menu items “119” through “127”; these parameters apply to the adjustment of the Parametric Microphone Equalizer when the speech processor is disabled. Menu items “128” through “136” apply to the adjustment of the Parametric Microphone Equalizer when the speech processor is engaged.

7. Touch **[SELECT]** on the LCD, then rotate the **MULT** knob to perform adjustments to a particular Menu item.
8. Press and hold the **PTT** switch, and speak into the microphone while listening to the effect of the changes you are making. Because the overall effect on the sound will change with each adjustment, you should make several passes through each adjustment area, to be sure that you are achieving the optimum settings.
9. When you have completed all adjustments, touch **[ENTER]** on the LCD to save the new settings.
10. Press the **MENU(SETUP)** button or touch **[BACK]** on the LCD to exit to normal operation. If you only touch **[BACK]** momentarily to exit, none of the changes you performed will be stored.

ADVICE:

To roll off excessive bass response in a wide-range studio microphone, try putting a 10 dB null at 100 Hz with a bandwidth of “1” or “2”, do about a 3 dB null centered on 800 Hz with a bandwidth of “3,” and then put an 8 dB peak centered on 2100 Hz with a bandwidth of “1.” These are starting recommendations; each microphone and user’s voice will be different, often requiring different settings.

ENHANCING TRANSMIT SIGNAL QUALITY

PARAMETRIC MICROPHONE EQUALIZER (SSB/AM/FM MODE)

Activating the Parametric Microphone Equalizer

1. Adjust [MIC GAIN] on the LCD, as described on page ##.
2. Press the **F(M-LIST)** button, then touch [MIC-EQ] on the LCD to select "ON". If you use the Parametric Microphone Equalizer with the speech processor engaged, press the **F(M-LIST)** button, then touch [PROC] on the LCD to select "ON".
The "MIC EQ" (and "PROC") will appear in the display, confirming that the Parametric Microphone Equalizer is engaged.
3. Press the **PTT** switch on the microphone, and speak into the microphone in a normal voice level.
4. To switch the Parametric Microphone Equalizer off, touch [MIC-EQ] on the LCD again until the "MIC EQ" icon disappears.

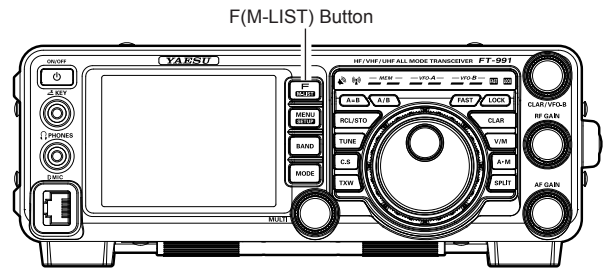

3-STAGE PARAMETRIC EQUALIZER ADJUSTMENTS (SPEECH PROCESSOR: "OFF")		
Center Frequency	"119 PRMTRC EQ1 FREQ"	"100" (Hz) ~ "700" (Hz) / "OFF"
	"122 PRMTRC EQ2 FREQ"	"700" (Hz) ~ "1500" (Hz) / "OFF"
	"125 PRMTRC EQ3 FREQ"	"1500" (Hz) ~ "3200" (Hz) / "OFF"
Parametric Gain	"120 PRMTRC EQ1 LEVEL"	(Low) "-20" (dB) ~ "+10" (dB)
	"123 PRMTRC EQ2 LEVEL"	(Mid) "-20" (dB) ~ "+10" (dB)
	"126 PRMTRC EQ3 LEVEL"	(High) "-20" (dB) ~ "+10" (dB)
Q (Bandwidth)	"121 PRMTRC EQ1 BWTH"	(Low) "1" ~ "10"
	"124 PRMTRC EQ2 BWTH"	(Mid) "1" ~ "10"
	"127 PRMTRC EQ3 BWTH"	(High) "1" ~ "10"

3-STAGE PARAMETRIC EQUALIZER ADJUSTMENTS (SPEECH PROCESSOR: "ON")		
Center Frequency	"128 P-PRMTRC EQ1 FREQ"	"100" (Hz) ~ "700" (Hz) / "OFF"
	"131 P-PRMTRC EQ2 FREQ"	"700" (Hz) ~ "1500" (Hz) / "OFF"
	"134 P-PRMTRC EQ3 FREQ"	"1500" (Hz) ~ "3200" (Hz) / "OFF"
Parametric Gain	"129 P-PRMTRC EQ1 LEVEL"	(Low) "-20" (dB) ~ "+10" (dB)
	"132 P-PRMTRC EQ2 LEVEL"	(Mid) "-20" (dB) ~ "+10" (dB)
	"135 P-PRMTRC EQ3 LEVEL"	(High) "-20" (dB) ~ "+10" (dB)
Q (Bandwidth)	"130 P-PRMTRC EQ1 BWTH"	(Low) "1" ~ "10"
	"133 P-PRMTRC EQ2 BWTH"	(Mid) "1" ~ "10"
	"136 P-PRMTRC EQ3 BWTH"	(High) "1" ~ "10"

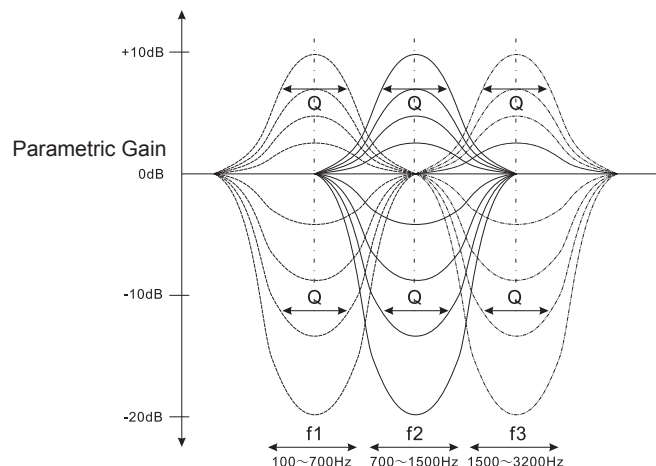

ENHANCING TRANSMIT SIGNAL QUALITY

USING THE SPEECH PROCESSOR (SSB MODE)

The **FT-991** Speech Processor is designed to increase “talk power” by increasing the average power output (via a sophisticated compression technique) and adjusting the audio quality to the menu settings (“128 P-PRMTRC EQ1 FREQ”, “131 P-PRMTRC EQ2 FREQ”, “134 P-PRMTRC EQ3 FREQ”). The result is improved intelligibility when conditions are difficult.

1. Adjust [**MIC GAIN**] on the LCD, as described on page ##.
2. Touch [**METER**] on the LCD to select “COMP” (Compression) meter.
3. Press the **F(M-LIST)** button, then touch [**PROC**] on the LCD to select “ON”.

The “**PROC**” will appear in the display, confirming that the Speech Processor is engaged.

4. Press the **PTT** switch on the microphone, and speak into the microphone in a normal voice level.
5. Adjust the **MULT** knob to set the compression level within the 5 dB to 10 dB range.
6. To switch the Speech Processor off, touch [**PROC**] on the LCD once more. The “**PROC**” will turn off, confirming that the Speech processor is turned off.

ADVICE:

- You may adjust the Parametric Microphone Equalizer when the speech processor is engaged, using Menu Items “128” through “136”. See page ## for details.

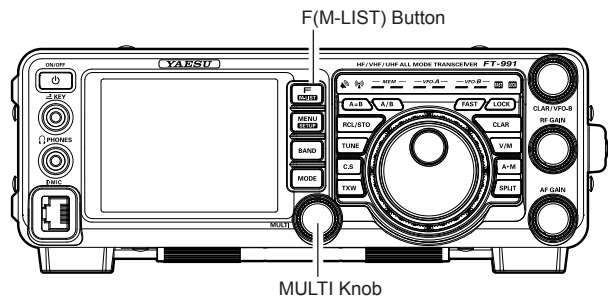

ENHANCING TRANSMIT SIGNAL QUALITY

ADJUSTING THE SSB TRANSMITTED BANDWIDTH (SSB MODE)

For transmission on SSB, a default bandwidth of 2.4 kHz is provided. This bandwidth provides reasonable fidelity along with good talk power, and is typical of the bandwidth used for decades for SSB transmission. The bandwidth may be varied by the operator, to provide different levels of fidelity or talk power, according to your preferences.

Here are the steps to adjust the SSB transmit bandwidth:

1. Press the **MENU(SETUP)** button to engage the Menu.
2. Rotate the **MULTI** knob to select Menu item “110 SSB TX BPF”.
3. Touch [**SELECT**] on the LCD, then rotate the **MULTI** knob to select the desired bandwidth. The available selections are: 100-3000 Hz, 100-2900 Hz, 200-2800 Hz, 300-2700 Hz, and 400-2600 Hz. The default is 300-2700 Hz. A wider bandwidth will provide greater fidelity. A narrow bandwidth will compress the available transmitter power into less spectrum, resulting in more “talk power” for DX pile-ups.
4. Touch [**ENTER**] on the LCD to save the new setting.
5. Press the **MENU(SETUP)** button or touch [**BACK**] on the LCD to exit to normal operation.

ADVICE:

The Transmit Monitor function is a very helpful way to confirm the effect that changing the bandwidth will have on fidelity. With [**MONI**] displayed by pressing the **F(M-LIST)** button, you will be able to hear the difference in sound quality as you make changes.

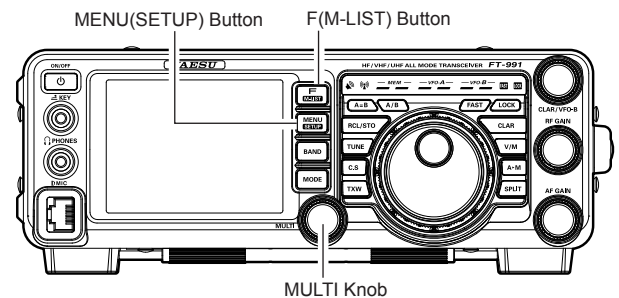

QUICK POINTS:

The higher fidelity associated with wide bandwidth will be particularly enjoyable on the low bands during local rag-chew QSOs.

TRANSMITTER CONVENIENCE FEATURES

VOICE MEMORY (SSB/AM/FM MODES: REQUIRES OPTIONAL DVS-6 AND FH-2)

You may utilize the Voice Memory capability of the **FT-991** for repetitive messages. The Voice Memory system includes five memories capable of storing up to 20 seconds of voice audio each. The maximum that any memory can hold is 20 seconds.

Voice Memory Operation from the FH-2 Remote Control Keypad

You may also utilize the Voice Memory capability of the **FT-991** from the optional **FH-2** Remote Control Keypad, which plugs into the rear panel's **REM/ALC** jack.

Recording Your Own Voice in Memory

1. Select the LSB, USB, AM, or FM mode using the front panel **MODE** button.
2. Adjust **[MIC GAIN]** on the LCD, as described on page ##.
3. Press the **[MEM]** key on the **FH-2**. A blinking "REC" icon will appear in the display.

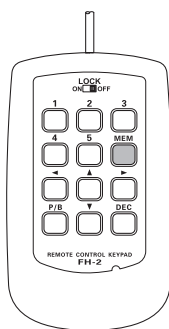

4. Press any of the **FH-2**'s keys numbered **[1]** through **[5]** to select that memory storage register.

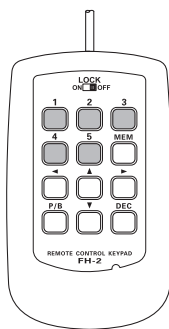

ADVICE:

If you do not press the **PTT** key (see next step) within five seconds, the memory storage process will be cancelled.

5. Press the microphone's **PTT** switch momentarily. The "REC" icon will glow steadily and recording will begin.
6. Speak into the microphone in a normal voice level to record the message (such as "CQ DX, CQ DX, this is W 6 Delta X-Ray Charlie, W 6 Delta X-Ray Charlie, Over"). Remember that the time limit for recording any message is 20 seconds.

7. Press the **FH-2 [MEM]** key to terminate the message storage process.

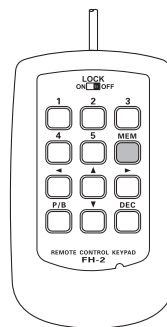

Checking Your Recording

1. Be sure that **[MOX]** and **[BK-IN]** on the LCD displayed by pressing the **F(M-LIST)** button are "Off".
2. Press the **FH-2 [1] ~ [5]** key (whichever one you just recorded in). The "PLAY" icon will appear in the display and you will hear the contents of the Voice Memory you just recorded.

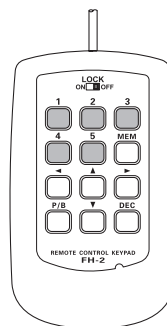

ADVICE:

You may adjust the playback level of the recording via Menu item "009 RX OUT LEVEL".

TRANSMITTER CONVENIENCE FEATURES

VOICE MEMORY (SSB/AM/FM MODES: REQUIRES OPTIONAL DVS-6 AND FH-2)

Transmitting the Recorded Message

1. Select the LSB, USB, AM, or FM mode using the front panel **MODE** button.
2. Press the front panel **F(M-LIST)** button, then touch **[BK-IN]** on the LCD.
3. Press the **FH-2 [1] ~ [5]** key (whichever one you just recorded in). A “**PLAY**” icon will appear in the display and the message will be transmitted.

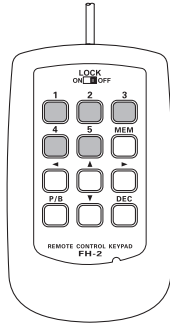

ADVICE:

You may adjust the transmit (audio) level of the recording via Menu item “010 TX OUT LEVEL”.

TRANSMITTER CONVENIENCE FEATURES

VOX (SSB/AM/FM MODES: AUTOMATIC TX/RX SWITCHING USING VOICE CONTROL)

Instead of using the microphone **PTT** switch or **[MOX]** displayed by pressing the **F(M-LIST)** button to activate the transmitter, the VOX (Voice Operated TX/RX Control) system provides hands-free, automatic activation of the transmitter, based on voice input into the microphone.

1. Press the **F(M-LIST)** button, then touch **[VOX]** on the LCD to select “ON”. The “**VOX**” will appear in the display.
2. Without pressing the **PTT** switch, speak into the microphone in a normal voice level. When you start speaking, the transmitter should be activated automatically. When you finish speaking, the transceiver should return to the receive mode (after a short delay).
3. To cancel VOX and return to **PTT** operation, touch **[VOX]** on the LCD once more. The “**VOX**” will turn off, signifying that the VOX circuitry has been turned off.

ADVICE:

- ❑ The VOX Gain may be adjusted to prevent accidental transmitter activation in a noisy environment. To adjust the VOX Gain:
 - 1) Activate the VOX circuitry, if necessary.
 - 2) Press the **MENU(SETUP)** button to engage the Menu mode.
 - 3) Rotate the **MULTI** knob to select Menu item “143 VOX GAIN”, then touch **[SELECT]** on the LCD.
 - 4) While speaking into the microphone, rotate the **MULTI** knob to the point where the transmitter is quickly activated by your voice, without background noise causing the transmitter to activate.
 - 5) When you satisfied with the setting, touch **[ENTER]** on the LCD to save the new setting.
 - 6) Press the **MENU(SETUP)** button or touch **[BACK]** on the LCD to exit to normal operation.
- ❑ The “Hang-Time” of the VOX system (the transmit/receive delay after the cessation of speech) may also be adjusted via the Menu mode. The default delay is 500 msec. To set a different delay time:
 - 1) Activate the VOX circuitry, if necessary.
 - 2) Press the **MENU(SETUP)** button to engage the Menu mode.
 - 3) Rotate the **MULTI** knob to select Menu item “144 VOX DELAY”, then touch **[SELECT]** on the LCD.
 - 4) Rotate the **MULTI** knob while saying a brief syllable like “Ah” and listening to the hang time for the desired delay.
 - 5) When you satisfied with the setting, touch **[ENTER]** on the LCD to save the new setting.
 - 6) Press the **MENU(SETUP)** button or touch **[BACK]** on the LCD to exit to normal operation.

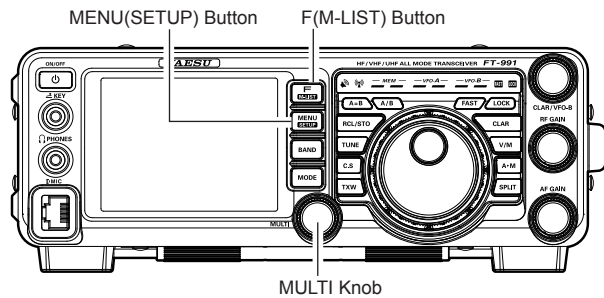

- ❑ The Anti-Trip setting adjusts the level of negative receiver audio feedback to the microphone, to prevent receiver audio from activating the transmitter (via the microphone). This setting can also be adjusted via Menu item “145 ANTI VOX GAIN”.
- ❑ VOX operation may be engaged on either Voice modes (SSB/AM/FM) or on AFSK-based Data modes. Use Menu item “142 VOX SELECT” (the selections are “MIC” and “DATA”).

TRANSMITTER CONVENIENCE FEATURES

MONITOR (SSB/AM/FM MODES)

You may listen to the quality of your transmitted signal using the Monitor feature.

1. Press the **F(M-LIST)** button, then touch **[MONI]** on the LCD. The “**MONI**” will appear on the TFT display.
2. During transmission, rotate the **MULTI** knob to adjust the audio level in the Headphones or speaker. Clockwise rotation of this knob will increase the volume level.
3. To switch the Monitor off again, touch **[MONI]** on the LCD once more. Confirming that the Monitor is now disengaged.

ADVICE:

- Because the Monitor feature samples the transmitter IF signal, it can be very useful for checking the adjustment of the Speech Processor or Parametric Equalizer on SSB, and for checking the general signal quality on AM and FM.

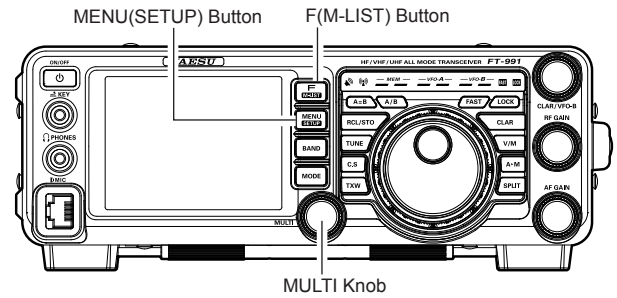

TRANSMITTER CONVENIENCE FEATURES

SPLIT-FREQUENCY OPERATION

A powerful capability of the **FT-991** is its flexibility in Split Frequency operation using the VFO-A and VFO-B frequency registers. This makes the **FT-991** especially useful for high-level DX-peditions. The Split operation capability is very advanced and easy to use.

1. Rotate the Main Tuning Dial knob to set the desired RX frequency.
2. Press the **A/B** button, then rotate the Main Tuning Dial knob to set the desired split TX frequency.
3. Press the **A/B** button, then press the **SPLIT** button. The VFO-B frequency will appear in the TFT display and the LED indicators will look like as below:
VFO-A RX Indicator: "ON" (LED glows Green)
VFO-A TX Indicator: "OFF" (LED Off)
VFO-B RX Indicator: "OFF" (LED Off)
VFO-B TX Indicator: "ON" (LED glows Red)

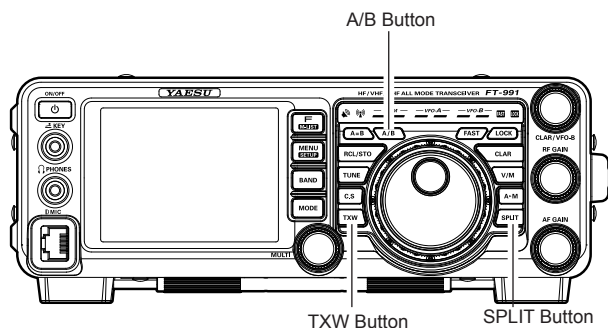

During Split operation, the VFO-A register will be used for reception, while the VFO-B register will be used for transmission. If you press the **SPLIT** button once more, Split operation will be cancelled.

ADVICE:

- During Split operation, pressing the **A/B** button will reverse the contents of the VFO-A and VFO-B. Press the **A/B** button once more to return to the original frequency alignment.
- During Split operation you may listen to the TX frequency temporarily while pressing the **TXW** button located on the bottom left of the Main Tuning Dial knob. While pressing the **TXW** button during split operations, the frequency on the transmission side can be changed.
- It is possible to set different operating modes (for example, LSB and USB) on the two VFOs used during Split operation.
- During Split operation it is also possible to set VFO-A and VFO-B to different Amateur bands if you use a multi band antenna.

Quick Split Operation

The Quick Split feature allows you to set a one-touch offset of +5 kHz to be applied to your radio's VFO-B (transmit) frequency, compared to the VFO-A frequency.

1. Start with regular transceiver operation on the VFO-A.
VFO-A RX Indicator: "ON" (LED glows Green)
VFO-A TX Indicator: "ON" (LED glows Red)
VFO-B RX Indicator: "OFF" (LED Off)
VFO-B TX Indicator: "OFF" (LED Off)
2. Press and hold in the **SPLIT** button for one second to engage the Quick Split feature, and apply a frequency 5 kHz above the VFO-A frequency to the VFO-B frequency register.
The VFO configuration will then be:
VFO-A RX Indicator: "ON" (LED glows Green)
VFO-A TX Indicator: "OFF" (LED Off)
VFO-B RX Indicator: "OFF" (LED Off)
VFO-B TX Indicator: "ON" (LED glows Red)
3. Press and hold in the **SPLIT** switch for one second to increment the Sub (VFO-B) frequency another +5 kHz.

QUICK POINTS:

- The operating mode applied to the VFO-B register will be the same as that in use on the VFO-A register.
- The offset of VFO-B from VFO-A is programmed via the Menu and is set to +5 kHz at the factory. However, other offsets may be selected using the following procedure:

~~~~~

1. Press the **MENU(SETUP)** button to engage the Menu mode.
2. Rotate the **MULTI** knob to select Menu item "034 QUICK SPLIT FREQ".
3. Touch [**SELECT**] on the LCD, then rotate the **MULT** knob to select the desired offset. The available selections are -20kHz ~ +20kHz (factory default: +5 kHz).
4. Touch [**ENTER**] button to save the new setting.
5. Press the **MENU(SETUP)** button or touch [**BACK**] on the LCD to exit to normal operation.

# CW MODE OPERATION

The powerful CW operating capabilities of the **FT-991** permit operation using an electronic keyer paddle, a “straight key”, or a computer-based keying device.

## SETUP FOR STRAIGHT KEY (AND STRAIGHT KEY EMULATION) OPERATION

Before starting, connect your key line(s) to the front panel **KEY** jack. Be sure **[BK-IN]** displayed by pressing the **F(M-LIST)** button is turned off for now.

1. Press the **MODE** button, then touch **[CW-USB]** on the LCD. The “**USB CW**” icon will appear in the display. The “**MONI**” icon will appear in the TFT display; and the CW monitor is activated.

### ADVICE:

If you press and hold the **MODE** button, you will engage the “CW Reverse” mode, whereby the “opposite” sideband injection is used, compared to the “normal” sideband. The “**LSB CW**” icon will appear in the display if you select CW Reverse.

2. Rotate the Main Tuning Dial knob to select the desired operating frequency.
3. Press the **F(M-LIST)** button, then touch **[BK-IN]** on the LCD to engage automatic activation of the transmitter when you close the CW key. The “**BK-IN**” icon will appear in the TFT display.

### ADVICE:

- When you close your CW key, the transmitter will automatically be activated, and the CW carrier will be transmitted. When you release the key, transmission will cease, and after a brief delay, receive will be restored. The delay time is user-programmable per the discussion on page ##.
  - As shipped from the factory, the **FT-991** TX/RX system for CW is configured for “Semi-break-in” operation. However, using Menu item “057 CW BK-IN”, you may change this setup for full break-in (QSK) operation, whereby the switching is quick enough to hear incoming signals in the spaces between the dots and dashes of your transmission. This may prove very useful during contest and traffic handling operations.
4. Operation using your CW key may now proceed.

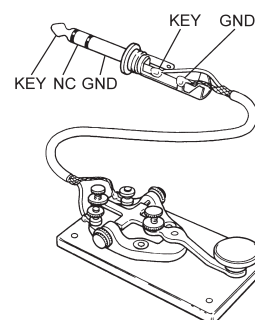
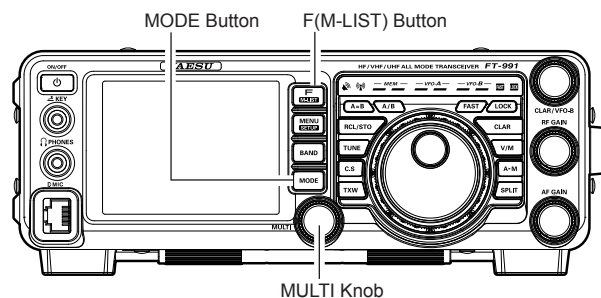

- If you set **[BK-IN]** displayed by pressing the **F(M-LIST)** button to Off, you may practice sending CW with the sidetone only, without having the signal go out over the air.
- If you reduce power via **[PROC]** displayed by pressing the **F(M-LIST)** button, the ALC meter reading will increase; this is normal and does not indicate any problem whatsoever (because increased ALC voltage is being used to lower the power).

### TERMINOLOGY:

#### Semi-break-in

This is a pseudo-“VOX” mode used on CW, whereby the closure of the CW key will engage the transmitter, and release of the key will allow the receiver to recover after a short delay. No signals will be heard during the spaces between dots and dashes (unless the sending speed is extremely slow).

#### Full break-in

Full break-in (also known as “Full QSK”) involves very fast switching between transmit and receive, incoming signals may be heard between the dots and dashes as you send them. This allows you to hear a station that suddenly starts transmitting on your frequency, while you are in the midst of a transmission.

## USING THE BUILT-IN ELECTRONIC KEYS

Connect the cable from your keyer paddle to the front panel **KEY** jack.

1. Press the **MODE** button, then touch [**CW-USB**] on the LCD. The “**USB CW**” icon will appear in the display. The “**MONI**” icon will appear in the TFT display; and the CW monitor is activated.

### ADVICE:

If you press the “CW” mode, you will engage the “CW Reverse” mode, whereby the “opposite” sideband injection is used, compared to the “normal” sideband. The “**LSB CW**” icon will appear in the display if you select CW Reverse.

2. Rotate the Main Tuning Dial knob to select the desired operating frequency.
3. Press the **F(M-LIST)** button, then touch [**KEYER**] on the LCD to select “ON”. The “**KEYER**” will appear in the display, confirming that the built-in Electronic Keyer is now active.
4. Touch [**SPEED**] on the LCD repeatedly to set the desired sending speed (4 ~ 60 WPM).

### ADVICE:

- The display will show the keying speed for 3 seconds whenever [**SPEED**] on the LCD is touched.
  - When you press either the “Dot” or “Dash” side of your paddle, the CW keying tone will automatically be generated.
5. Touch [**BK-IN**] on the LCD to engage automatic activation of the transmitter when you press either the “Dot” or “Dash” side of your paddle. The “**BK-IN**” icon will appear in the TFT display.
  6. CW operation utilizing your paddle may now commence.

### ADVICE:

When you utilize your keyer paddle, the transmitter will automatically be activated, and the CW characters (or a string of dots and dashes) will be transmitted. When you release the keyer paddle contacts, transmission will cease, and reception will be restored after a brief delay. The delay time is user-programmable, per the discussion on page ##.

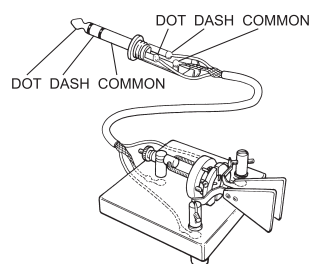
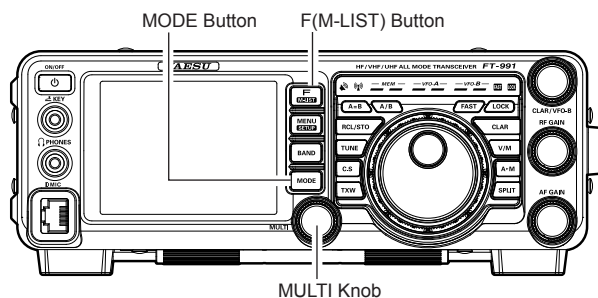

- If you set [**BK-IN**] displayed by pressing the **F(M-LIST)** button to Off, you may practice sending CW with the sidetone only, without having the signal go out over the air.
- If you reduce power via [**PROC**] displayed by pressing the **F(M-LIST)** button, the ALC meter reading will increase; this is normal and does not indicate any problem whatsoever (because increased ALC voltage is being used to lower the power).

## USING THE BUILT-IN ELECTRONIC KEYS

### Full Break-in (QSK) Operation

As shipped from the factory, the **FT-991** TX/RX system for CW is configured for “Semi-break-in” operation. However, this setup may be changed to full break-in (QSK) operation using Menu item “057 CW BK-IN”. With full break-in QSK, the TX/RX switching is quick enough to hear incoming signals in the spaces between the dots and dashes of your transmission.

1. Press the **MENU(SETUP)** button to engage the Menu.
2. Rotate the **MULTI** knob to select Menu item “057 CW BK-IN”.
3. Press the [**SELECT**] button, then rotate the **MULTI** knob to set this Menu item to “FULL”.
4. When your adjustments are complete, touch [**ENTER**] on the LCD to save the new setting.
5. Press the **MENU(SETUP)** button or touch [**BACK**] on the LCD to exit to normal operation.

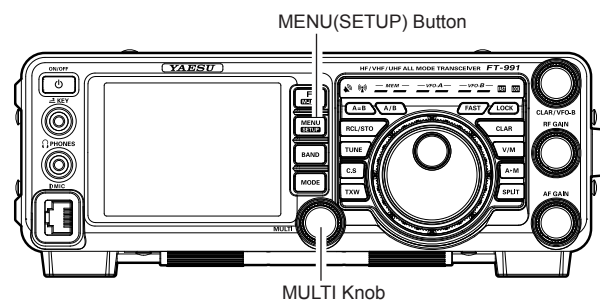

A number of interesting and useful features are available during Electronic Keyer operation.

### Setting the Keyer Weight (Dot/Dash) Ratio

This Menu item may be used to adjust the dot/dash ratio for the built-in Electronic Keyer. The default weighting is 3:1 (a dash is three times longer than a dot).

1. Press the **MENU(SETUP)** button to engage the Menu.
2. Rotate the **MULTI** knob to select Menu item “013 CW WEIGHT”.
3. Press the [**SELECT**] button, then rotate the **MULTI** knob to set the weight to the desired value. The available adjustment range is a Dot/Dash ratio of 2.5 ~ 4.5 (default value: 3.0).
4. When your adjustments are complete, touch [**ENTER**] on the LCD to save the new setting.
5. Press the **MENU(SETUP)** button or touch [**BACK**] on the LCD to exit to normal operation.

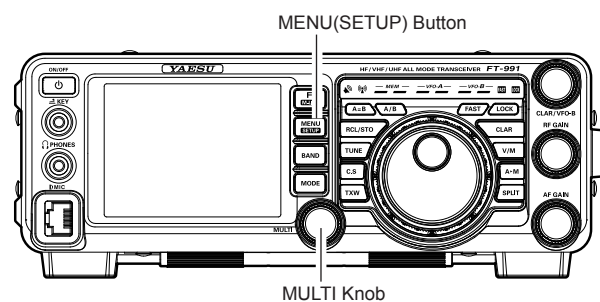

## USING THE BUILT-IN ELECTRONIC KEYS

### Selecting the Keyer Operating Mode

The configuration of the Electronic Keyer may be customized independently for the front panel **KEY** jack of the **FT-991**. This permits utilization of Automatic Character Spacing (ACS), if desired. This permits the use of an electronic keyer via the front jack and a straight key or computer-driven keying line via the rear panel jack.

1. Press the **MENU(SETUP)** button to engage the Menu.
2. Rotate the **MULTI** knob to select Menu item "011 KEYSER TYPE".
3. Press the [**SELECT**] button, then rotate the **MULTI** knob to set the keyer to the desired mode.

The available selections are:

**OFF:** The built-in Electronic Keyer is turned off ("straight key" mode).

**BUG:** Dots will be generated automatically by the keyer, but dashes must be sent manually.

**ELEKEY:** Both dots and dashes will be generated automatically when using a paddle.

**ACS:** Same as "ELEKEY" except that the spacing between characters is precisely set by the keyer to be the same length as a dash (three dots in length)

4. When your adjustments are complete, touch [**ENTER**] on the LCD to save the new setting.
5. Press the **MENU(SETUP)** button or touch [**BACK**] on the LCD to exit to normal operation.

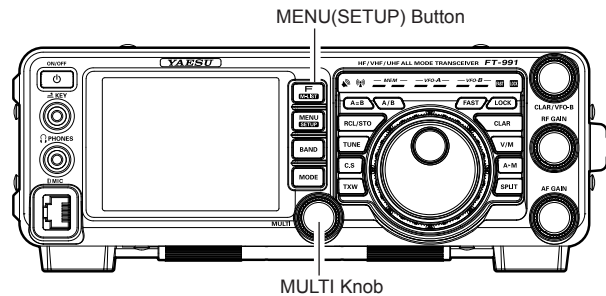

**ACS OFF**

Morse "E" & "T"

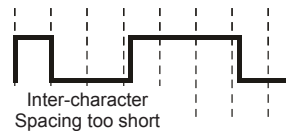

**ACS ON**

Morse "E" & "T"



## CW SPOTTING (ZERO-BEATING)

“Spotting” (zeroing in on another CW station) is a handy technique to ensure you and the other station are precisely on the same frequency.

The Tuning Offset Indicator in the display may also be moved so you can adjust your receiver frequency to center the incoming station on the pitch corresponding to that of your transmitted signal.

### Using the Auto Zeroing System

(Only when the optional FFT unit is installed)

Press the **F(M-LIST)** button, then touch **[ZIN]** on the LCD to adjust the receiving frequency to the zero-in automatically while receiving the CW signal.

### Using the SPOT System

Press the **F(M-LIST)** button, then touch **[SPOT]** on the LCD. Touch **[MONI]** on the LCD, the Spot tone will be heard through your speaker. This tone corresponds to the pitch of your transmitted signal. If you adjust the receiver frequency until the pitch of the received CW signal matches that of the Spot tone, your transmitted signal will be precisely matched to that of the other station.

Touch **[SPOT]** on the LCD again to turn the Spot tone off.

#### ADVICE:

- ❑ In a tough DX pile-up, you may actually want to use the SPOT system to find a “gap” in the spread of calling stations, instead of zeroing in precisely on the last station being worked by the DX station. From the DX side, if a dozen or more operators (also using Yaesu’s SPOT system) all call precisely on the same frequency, their dots and dashes merge into a single, long tone that the DX station cannot decipher. In such situations, calling slightly higher or lower in frequency may get your call through.

#### QUICK POINTS:

- ❑ The displayed frequency on CW normally reflects the “zero beat” frequency of your offset carrier. That is, if you were to listen on USB on 14.100.00 MHz to a signal with a 700 Hz offset, the “zero beat” frequency of that CW carrier would be 14.100.70 MHz; the latter frequency is what the **FT-991** displays, by default. However, you can change the display to be identical to what you would see on SSB by using Menu item “060 CW FREQ DISPLAY” and setting it to “DIRECT FREQ” instead of the default “PITCH OFFSET” setting.

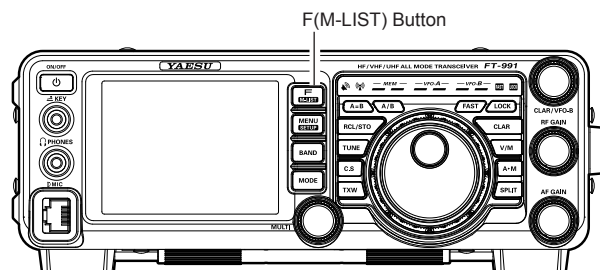



# CW CONVENIENCE FEATURES

## CW DELAY TIME SETTING

During semi-break-in (not QSK) operation, the hang time of the transmitter, after you have finished sending, may be adjusted to a comfortable value consistent with your sending speed. This is the functional equivalent of the “VOX Delay” adjustment used on voice modes, and the delay may be varied anywhere between 30 msec and 3 seconds via Menu item “064 CW BK-IN DELAY”.

1. Press the **F(M-LIST)** button, then touch **[BK-IN]** on the LCD to enable CW transmission (Menu item “057 CW BK-IN” must be set to “SEMI”).
2. Press the **MENU(SETUP)** button to enter the Menu mode.
3. Rotate the **MULTI** knob to select Menu item “058 CW BK-IN DELAY”, then touch **[SELECT]** on the LCD.
4. Start sending and rotate the **MULTI** knob to adjust the hang time, as you prefer for comfortable operation.
5. When your adjustments are complete, touch **[ENTER]** on the LCD to save the new setting.
6. Press the **MENU(SETUP)** button or touch **[BACK]** on the LCD to exit to normal operation.

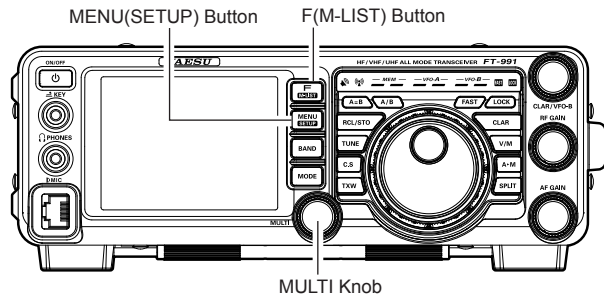

## CONTEST MEMORY KEYER (USING THE OPTIONAL FH-2 REMOTE CONTROL KEYPAD)

You may also utilize the CW message capability of the **FT-991** from the optional **FH-2** Remote Control Keypad, which plugs into the rear panel **REM/ALC** jack.

### Message Memory

Five memory channels capable of retaining 50 characters each are provided (using the PARIS standard for characters and word length).

*Example:* CQ CQ CQ DE W6DXC K (19 characters)

--- · · · · · --- · · · · · --- · · · · · --- · · · · · --- · · · · · --- · · · · · --- · · · · · --- · · · · · --- · · · · ·  
 (C) (Q) (C) (Q) (C) (Q) (D)(E) (W) (6) (D) (X) (C) (K)

### STORING A MESSAGE INTO MEMORY

1. Press the **MENU(SETUP)** button to enter the Menu mode.
2. Rotate the **MULTI** knob to select the CW Memory Register into which you wish to store the message; for now, we are just setting the message entry technique to (Keyer entry).  
 017 CW MEMORY 1  
 018 CW MEMORY 2  
 019 CW MEMORY 3  
 020 CW MEMORY 4  
 021 CW MEMORY 5
3. Touch [**SELECT**] on the LCD, then rotate the **MULTI** knob to set the selected CW Memory Register to "MESSAGE". If you want to use your keyer paddle for message entry on all memories, set all five Menu items (#017 ~ 021) to "MESSAGE".
4. Touch [**ENTER**] on the LCD to save the new setting.
5. Press the **MENU(SETUP)** button or touch [**BACK**] on the LCD to exit to normal operation.

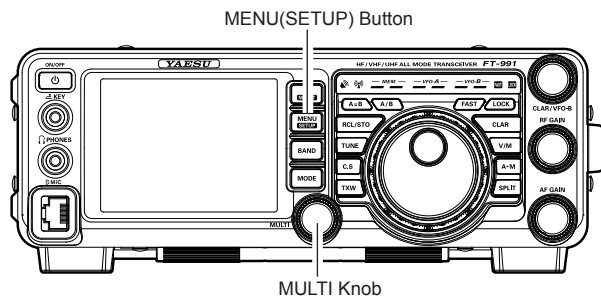

### TERMINOLOGY:

**PARIS Word Length:** By convention among CW and Amateur operators (utilized by ARRL and others), the length of one "word" of CW is defined as the length of the Morse Code characters spelling the word "PARIS". This character (dot/dash/space) length is used for the specific definition of code speed in "words per minute".

### Contest Number Programming

Use this process if you are starting a contest, or if you somehow get out of sync with the proper number in the middle of a contest.

1. Press the **MENU(SETUP)** button to enter the Menu mode.
2. Rotate the **MULTI** knob to select Menu item "016 CONTEST NUMBER". The current contest number appears on the TFT display.
3. Touch [**SELECT**] on the LCD, then rotate the **MULTI** knob to set the Contest Number to the desired value.

#### ADVICE:

- Touch [**BACK**] on the LCD to cancel the setting.
4. Touch [**ENTER**] on the LCD to save the new setting.

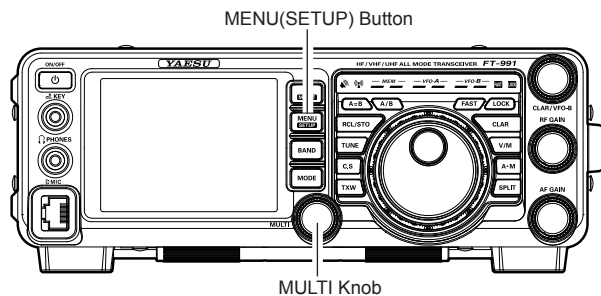

5. Press the **MENU(SETUP)** button or touch [**BACK**] on the LCD to exit to normal operation.

# CW CONVENIENCE FEATURES

## CONTEST MEMORY KEYER (USING THE OPTIONAL FH-2 REMOTE CONTROL KEYPAD)

### MESSAGE MEMORY PROGRAMMING (USING YOUR PADDLE)

1. Set the operating mode to CW.
2. Set **[BK-IN]** on the LCD to “Off”.
3. Turn the internal Electronic Keyer “On”.
4. Press the **[MEM]** key on the **FH-2**. A blinking “REC” icon will appear in the display.

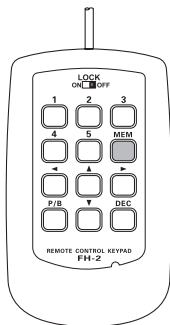

5. Press any of the **FH-2** keys numbered **[1]** through **[5]** to begin the memory storage process, and the “REC” icon will glow steadily.

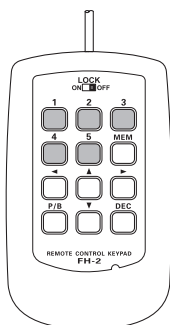

6. Send the desired message using your keyer paddle.

#### ADVICE:

If you do not start keying within ten seconds, the memory storage process will be cancelled.

7. Press the **[MEM]** key on the **FH-2** once more at the end of your message. Up to 50 characters may be stored in each of the five memories.

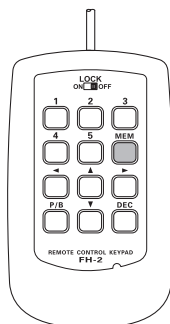

### CHECKING THE CW MEMORY CONTENTS

1. Be sure that Break-in is still turned “Off” by **[BK-IN]** on the LCD.
2. Touch **[MONI]** on the LCD to enable the CW monitor.
3. Press the **FH-2 [1] ~ [5]** key, whichever memory you just recorded in. You will hear the results in the sidetone monitor, but no RF energy will be transmitted.

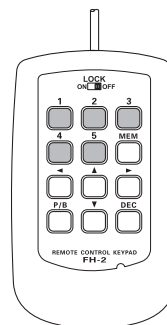

### ON-THE-AIR CW MESSAGE PLAYBACK

1. Touch **[BK-IN]** on the LCD to enable transmission. Either Full- or Semi-break-in will be engaged, depending on the setting of Menu item “057 CW BK-IN”.
2. Press the **FH-2 [1] ~ [5]** key, depending on which CW Memory Register message you wish to transmit. The programmed message will be transmitted on the air.

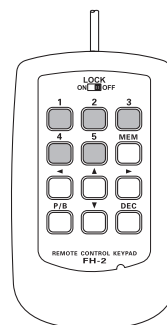

#### NOTE:

If you subsequently decide to use the “Text Memory” technique for memory storage, please note that a message stored using keyer paddle input will not be transferred over when you select “Text Memory technique” on a particular memory register (the Menu Mode Setting is set to “TEXT”).

# CW CONVENIENCE FEATURES

## CONTEST MEMORY KEYS (USING THE OPTIONAL FH-2 REMOTE CONTROL KEYPAD)

### TEXT Memory

The five channels of CW message memory (up to 50 characters each) may also be programmed using a text-entry technique. This technique is somewhat slower than when you send the message directly from your keyer paddle, but accuracy of character spacing is ensured. Be sure to enter the character “}” at the end of texts.

*Example 1:* CQ CQ CQ DE W6DXC K} (20 characters)

The sequential Contest Number (“Count up”) feature is another powerful feature of the CW Memory Keyer.

*Example 2:* 599 10 200 # K} (15 characters)

### TEXT MEMORY STORAGE

1. Press and hold in the **MENU(SETUP)** button for one second to enter the Menu mode.
2. Rotate the **MULTI** knob to select the CW Memory Register into which you wish to store the message; we are now setting the message entry technique to (Text entry).

017 CW MEMORY 1  
 018 CW MEMORY 2  
 019 CW MEMORY 3  
 020 CW MEMORY 4  
 021 CW MEMORY 5

#### ADVICE:

The following texts are programmed to the MEMORY 4 and MEMORY 5 in factory default.

MEMORY 4: DE FT-991 K}

MEMORY 5: R 5NN K}

3. Touch [**SELECT**] on the LCD, then rotate the **MULTI** knob to set the selected CW Memory Register to “TEXT”. If you want to use text message entry on all memories, set all five Menu items (#017 ~ 021) to “TEXT”.
4. Touch [**ENTER**] on the LCD to save the new setting.
5. Press the **MENU(SETUP)** button or touch [**BACK**] on the LCD to exit to normal operation.

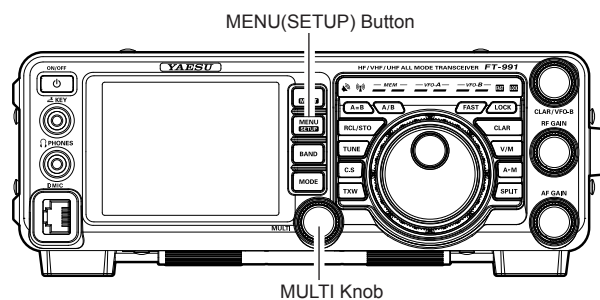

| TEXT | CW CODE | TEXT | CW CODE | TEXT | CW CODE | TEXT | CW CODE | TEXT | CW CODE | TEXT | CW CODE |
|------|---------|------|---------|------|---------|------|---------|------|---------|------|---------|
| !    | SN      | &    | AS      | +    | AR      | :    | OS      | ?    | IMI     | ^    | —       |
| "    | AF      | '    | WG      | ,    | MIM     | ;    | KR      | @    | @       | _    | IQ      |
| #    | —       | (    | KN      | -    | DU      | <    | —       | [    | —       | }    | —       |
| \$   | SX      | )    | KK      | .    | AAA     | =    | BT      | ¥(\) | AL      |      |         |
| %    | KA      | *    | —       | /    | DN      | >    | —       | }    | —       |      |         |

# CW CONVENIENCE FEATURES

## CONTEST MEMORY KEYS (USING THE OPTIONAL FH-2 REMOTE CONTROL KEYPAD)

### TEXT MESSAGE PROGRAMMING

1. Press the **MODE** button to set the operating mode to CW.
2. Be sure that Break-in is "Off" with [**BK-IN**] on the LCD, if necessary.
3. Press the **FH-2 [MEM]** key. A blinking "**REC**" icon will appear in the display.

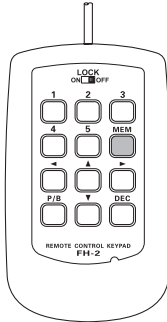

4. Press an **FH-2 [1] ~ [5]** key to select the desired CW Memory Register into which you wish to program the text, the blinking "**REC**" icon will disappear.

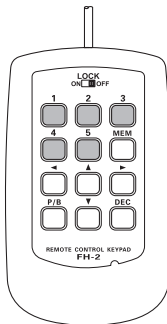

5. Use the **FH-2 [◀]** and [**▶**] keys to set the cursor position and use the **FH-2's [▲]** and [**▼**] keys to choose the letter/number to be programmed in each slot of the memory. In the case of the second example on the previous page the "**#**" character designates the slot where the Contest Number will appear.

### ADVICE:

You may also use the Main Tuning Dial knob and the **MULTI** knobs to program the message characters.

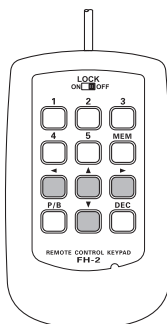

6. When the message is complete, add the "**}**" character at the end to signify the termination of the message.
7. Press and hold in the **FH-2 [MEM]** key for one second to exit, once all characters (including "**}**") have been programmed.

### CHECKING THE CW MEMORY CONTENTS

1. Be sure that Break-in is still turned "Off" with [**BK-IN**] on the LCD.
2. Touch [**MONI**] on the LCD to enable the CW monitor.
3. Press an **FH-2 [1] ~ [5]** key, whichever memory you just recorded in. You will hear the results in the sidetone, but no RF energy will be transmitted.

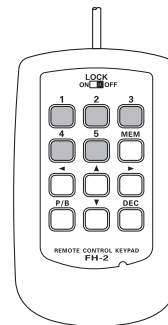

### ON-THE-AIR CW MESSAGE PLAYBACK

1. Touch [**BK-IN**] on the LCD to enable transmission. Either Full-break-in or Semi-break-in will be engaged, depending on the setting of Menu item "063 CW BK-IN".
2. Press an **FH-2 [1] ~ [5]** key, depending on which CW Memory Register message you wish to transmit. The programmed message will be transmitted on the air.

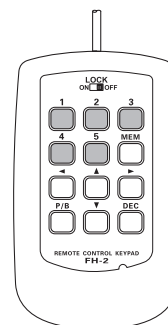

---

## CONTEST MEMORY KEYS (USING THE OPTIONAL FH-2 REMOTE CONTROL KEYPAD)

---

### NOTE:

If you subsequently decide to use the “Message Memory” technique for memory storage, please note that the contents of a message stored using text input will not be transferred over when you set entry to “Message Memory technique” on a particular memory register (the Menu Mode Setting is set to “MESSAGE”).

### Decrementing the Contest Number

Use this process if the current contest number gets slightly ahead of the actual number you want to send (in case of a duplicate QSO, for example).

Press the **FH-2 [DEC]** key momentarily. The current Contest Number will be reduced by one. Press of the **FH-2 [DEC]** key as many times as necessary to reach the desired number. If you go too far, use the “Contest Number Programming” technique described previously.

### Transmitting in the Beacon Mode

In “Beacon” mode, it is possible to repeatedly transmit any message programmed, either via paddle input, or via the “Text” input method. The time delay between message repeats may be set anywhere between 1 and 690 seconds (1 ~ 240 sec (1 sec/step) or 270 ~ 690 sec (30 sec/step)) via Menu item “014 BEACON TIME” If you do not wish the message to repeat in a “Beacon” mode, please set this Menu item to “OFF”.

To transmit the message:

1. Touch **[BK-IN]** on the LCD to enable transmission. Either Full-break-in or Semi-break-in will be engaged, depending on the setting of Menu item “057 CW BK-IN”.
2. Press an **FH-2 [1] ~ [5]** key. Repetitive transmission of the Beacon message will begin.

# FM MODE OPERATION

## BASIC OPERATION

1. Press the **MODE** button, then touch the corresponding key on the LCD to select the FM operating mode. The “**FM**” icon appears in the display.
2. Rotate the Main Tuning Dial knob to select the desired operating frequency. Pressing the microphone **UP** or **DWN** button will cause frequency change in 5 kHz steps.
3. Press the microphone **PTT** switch to transmit. Speak into the microphone in a normal voice level. Release the **PTT** switch to return to receive.
4. Adjustment of the microphone gain may be accomplished in two ways. At the factory, a default level has been programmed that should be satisfactory for most situations. However, using Menu item “077 FM MIC GAIN”, you may set a different fixed value, or choose the “MCVR” option, which then lets you use [**MIC GAIN**] on the LCD to set the microphone gain in the FM mode.

### **ADVICE:**

- The Transmit Monitor is another helpful way to verify proper adjustment of the FM MIC Gain. With [**MONI**] displayed by pressing the **F(M-LIST)** button, you will be able to hear the differences in deviation as you make adjustments.
- FM is only used in the 28 MHz, 50 MHz, 144 MHz, and 430 MHz Amateur bands covered by the **FT-991**. Please do not use FM on any other bands.

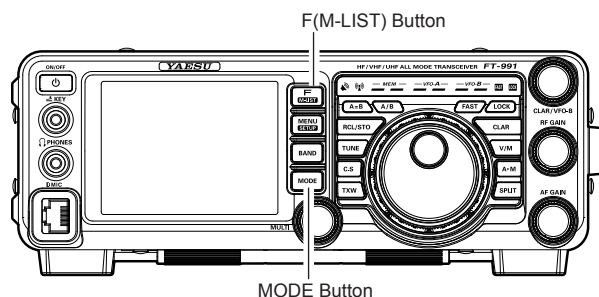

## REPEATER OPERATION

The **FT-991** may be utilized on 29 MHz, 50 MHz, 144 MHz, and 430 MHz repeaters.

1. Rotate the Main Tuning Dial knob to the output frequency (downlink) from the repeater.
2. If CTCSS Tone operation is desired/needed, press the **F(M-LIST)** button, then touch **[TONE]** on the LCD to engage the CTCSS mode.
3. Touch **[TONE]** on the LCD repeatedly to select the desired CTCSS mode. If you just need to send the uplink encoding tone, select "ENC." For encode/decode operation, choose "T.SQL" instead. The available choices are  
 "OFF" → "ENC (Tone Encoder)"  
                   → "T.SQL (Tone Squelch)" → "OFF"
4. Rotate the **MULTI** knob to select the desired CTCSS Tone to be used. A total of 50 standard CTCSS tones are provided (see the CTCSS Tone Chart).
5. Press the **F(M-LIST)** button, then touch **[RPT]** on the LCD to select the desired repeater shift direction. The selections are:  
 "SIMP" → "+" → "-" → "SIMP"  
 where "SIMP" represents "Simplex" operation (not used on a repeater).
6. Press and hold the microphone **PTT** switch to begin transmission. You will observe that the frequency has shifted to correspond to the programming you set up in the previous steps, and a "t" notation will appear on the "10 Hz" frequency digit while transmitting. Speak into the microphone in a normal voice level. Release the **PTT** switch to return to the receive mode.

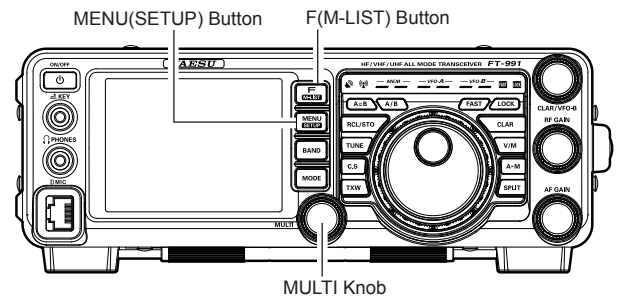

| CTCSS TONE FREQUENCY (Hz) |       |       |       |       |       |       |       |
|---------------------------|-------|-------|-------|-------|-------|-------|-------|
| 67.0                      | 69.3  | 71.9  | 74.4  | 77.0  | 79.7  | 82.5  | 85.4  |
| 88.5                      | 91.5  | 94.8  | 97.4  | 100.0 | 103.5 | 107.2 | 110.9 |
| 114.8                     | 118.8 | 123.0 | 127.3 | 131.8 | 136.5 | 141.3 | 146.2 |
| 151.4                     | 156.7 | 159.8 | 162.2 | 165.5 | 167.9 | 171.3 | 173.8 |
| 177.3                     | 179.9 | 183.5 | 186.2 | 189.9 | 192.8 | 196.6 | 199.5 |
| 203.5                     | 206.5 | 210.7 | 218.1 | 225.7 | 229.1 | 233.6 | 241.8 |
| 250.3                     | 251.4 | -     | -     | -     | -     | -     | -     |

### ADVICE:

- ❑ The conventional repeater shift used on 29 MHz is 100 kHz, while on the 50 MHz band the shift may vary between 500 kHz and 1.7 MHz (or more). To program the proper repeater shift, use Menu items "083 RPT SHIFT [28MHz]" (28 MHz), "084 RPT SHIFT [50MHz]" (50 MHz), "085 RPT SHIFT [144MHz]" (144 MHz), and "086 RPT SHIFT [430MHz]" (430 MHz) as appropriate.



## TONE SQUELCH OPERATION

You may also use “Tone Squelch” whereby your receiver will be kept silent until an incoming signal modulated with a matching CTCSS tone is received. The receiver squelch will then open in response to the reception of the required tone.

1. Rotate the Main tuning Dial to the output frequency (downlink) from the repeater.
2. If CTCSS Tone operation is desired/needed, press the **F(M-LIST)** button, then touch **[TONE]** on the LCD to engage the CTCSS mode.
3. Touch **[TONE]** on the LCD repeatedly to choose “T.SQL” from the available choices of  
“OFF” → “ENC (Tone Encoder)”  
→ “T.SQL (Tone Squelch)” → “OFF”
4. Rotate the **MULTI** knob to select the desired CTCSS Tone to be used. Fifty standard CTCSS tones are provided (see the CTCSS Tone Chart).
5. A “d” notation on the “1 Hz” frequency digit in the display will indicate that the Tone Decoder is engaged. A “t” notation on the “1 Hz” frequency digit while transmitting will indicate that the Tone Squelch is engaged.

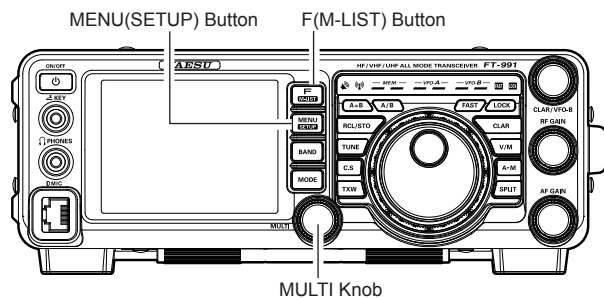



# MEMORY OPERATION

## STANDARD MEMORY OPERATION

The Standard Memory of the **FT-991** allows storage and recall of up to 99 memories, each storing frequency, mode, and a wide variety of status information, detailed previously. Memories may be grouped into as many as six Memory Groups, and additionally you get nine pairs of band-limit (PMS) memories along with five QMB (Quick Memory Bank) memories.

### Memory Storage

1. Set VFO-A up with the frequency, mode, and status, the way you want to have it stored.
2. Press the **A►M** button momentarily; the current channel number will start blinking in the display and the “**MCK**” notation will appear.
3. Rotate the **MULTI** knob to select the memory channel that you wish to store the data on.
4. Press and hold in the **A►M** button for one second to store the frequency and other data into the selected memory channel. A double beep will confirm that you have held the **A►M** button in long enough.

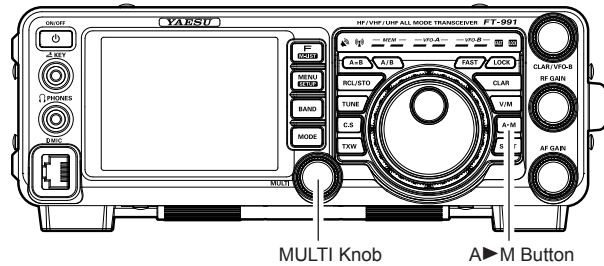

### Memory Channel Recall

1. Press the **V/M** button, if necessary, to enter the “Memory mode”.
2. Press the **F(M-LIST)** button, then touch **[MCH]** on the LCD. A memory channel number and the “**MCH**” notation will appear in the display.
3. After touching **[MCH]** on the LCD, you may rotate the **MULTI** knob to select the desired memory channel.

#### ADVICE:

To work within a particular Memory Group, press the **F(M-LIST)** button, then touch **[GRP]** on the LCD. Rotate the **MULTI** knob to select the desired Memory Group, then touch **[ENTER]** on the LCD (the “**MCH**” notation will appear instead of the “**GRP**”); you may now choose the memory channel within the selected Memory Group.

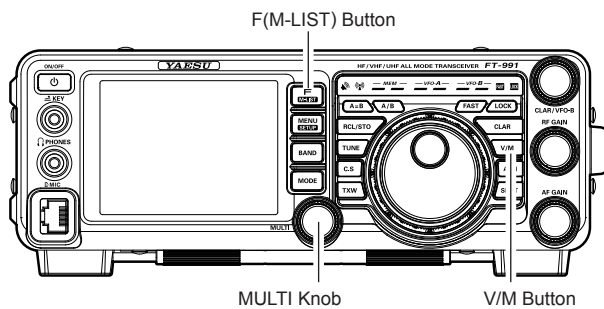

## STANDARD MEMORY OPERATION

### Labeling Memories

You may wish to append an Alphanumeric “Tag” (label) to a memory or memories, to aid in recollection of the channel’s use (such as a club name, etc.). To do this:

1. Press the **V/M** button, if necessary, to enter the “Memory Mode”.
2. Press and hold in the **F(M-LIST)** button.  
The data stored in the currently selected memory channel will be displayed on the TFT.
3. Rotate the **MULTI** knob to recall the memory channel that you wish to append a label.
4. Touch **[TAG]** on the LCD.  
A blinking cursor will appear on the first digit.
5. Touch a key on the LCD to enter the letters, numbers, or symbols of the desired label.
6. Repeat step 5 to program the remaining letters, numbers, or symbols of the desired label. 18 characters may be used in the creation of a label.  
Use **[◀]** and **[▶]** on the LCD to set the cursor position and **[◀]** on the LCD to erase a letter at the left of the cursor.
7. When you have completed the creation of the label, touch **[ENT]** on the LCD.
8. Press the **F(M-LIST)** button to save the new setting and return to normal operation.

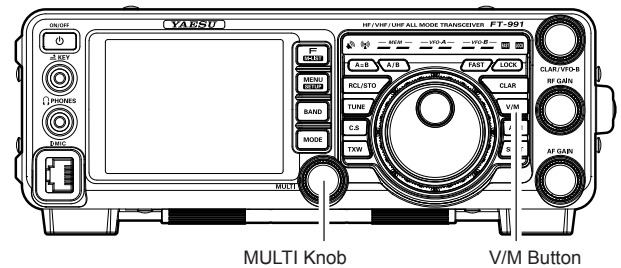

MULTI Knob

V/M Button

### Checking a Memory Channel Status

Before programming a channel into memory, you can check the current contents of that channel without the danger of over-writing the channel accidentally.

1. Press the **A▶M** button momentarily.  
The data stored in the currently selected memory channel will be displayed on the TFT. However, since you are only checking the contents of the memory channel, your radio will not have moved to the memory channel frequency.
2. Rotate the **MULTI** knob to select a different memory channel. To exit from the Memory Check mode, press the **A▶M** button momentarily once more.

#### ADVICE:

- While the Memory Check function is engaged, the memory channel number will blink in the display.
- While operating in the VFO mode, using Memory Check, you may store the current VFO frequency into the selected memory by pressing and holding in the **A▶M** button for one second (until the double beep). Conversely, if you wish to write the contents of the current memory into the VFO-A register, press the **V/M** button.

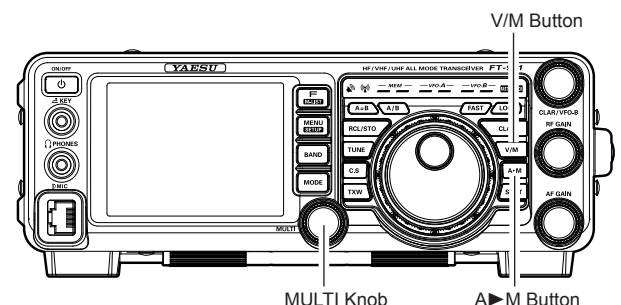

MULTI Knob

A▶M Button

## STANDARD MEMORY OPERATION

### Erasing Memory Channel Data

1. Press and hold in the **F(M-LIST)** button.
2. Rotate the **MULTI** knob to select the memory channel that you would like to erase.
3. Touch **[ERASE]** on the LCD.

#### ADVICE:

- The **FT-991** can not erase the memory channels “01” (and “501” through “510”: U.S. version).
- If you make a mistake and wish to restore the memory’s contents, just repeat steps (1) through (3) above.

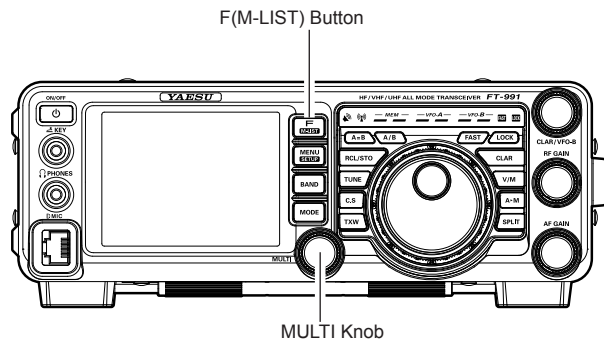

## STANDARD MEMORY OPERATION

### Memory Tune Operation

You may freely tune off from any memory channel in a “Memory Tune” mode, this is similar to VFO operation. So long as you do not over-write the contents of the current memory, Memory Tune operation will not alter the contents of the memory channel.

1. Press the **V/M** button to recall any memory channel.
2. Press the **F(M-LIST)** button, then touch **[MCH]** on the LCD.
3. Rotate the **MULTI** knob to select the memory channel.
4. Rotate the Main Tuning Dial knob; you will now observe that the memory channel frequency is changing.

#### ADVICE:

- During Memory Tune operation, you may change operating modes, and engage the offset Clarifier, if desired.
5. Press the **V/M** button momentarily to return to the originally memorized frequency of the current memory channel. One more press of the **V/M** button will return to VFO operation.

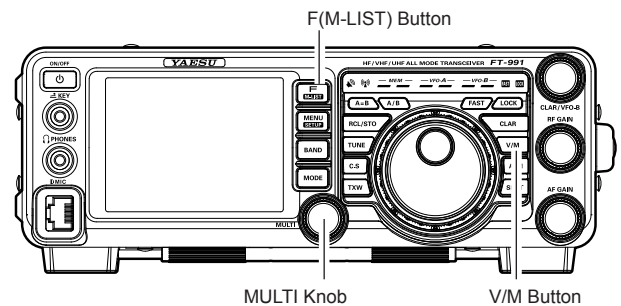

#### NOTE:

Computer software programs utilizing the CAT system interface port may presume that the transceiver is operating in the VFO mode, for certain features like “band mapping” and/or frequency logging, because the “Memory Tune” mode so closely resembles the VFO mode. Be sure that you have the **FT-991** operating in a control mode compatible with your software’s requirements. Use the VFO mode if you’re not sure.

# MEMORY OPERATION

## MEMORY GROUPS

Memory channels may be arranged into as many as six convenient groups, for easy identification and selection. For example, you might want to designate memory groups for AM BC stations, short-wave broadcast stations, contest frequencies, repeater frequencies and PMS limits, or any other groupings you like.

Each memory group is capable of holding up to 20 memory channels (except Memory Group 01: it is 19 memory channels, and the Group size is fixed). When a memory channel is grouped, the channel numbers change to correspond to the chart below:

### Memory Group Assignment

1. Press the **MENU(SETUP)** button to enter the Menu mode.
2. Rotate the **MULTI** knob to select Menu item “033 MEM GROUP”.
3. Touch **[SELECT]** on the LCD, then rotate the **MULTI** knob to set this Menu item to “ENABLE” (the default setting is “DISABLE”).
4. Touch **[ENTER]** on the LCD to save the new setting.
5. Press the **MENU(SETUP)** button or **[BACK]** on the LCD to exit. Operation will now be restricted to the six Memory Groups.

To cancel Memory Group operation, repeat steps (1) through (4) above, choosing “DISABLE” in step (3).

#### ADVICE:

To avoid confusion, note that the PMS memory group and the PMS memories “P-1L” through “P-9U” will be so designated.

### Choosing the Desired Memory Group

You may recall memories just within a particular Memory Group, if desired.

1. Press the **V/M** button, if necessary, to enter the “Memory” mode.
2. Press the **F(M-LIST)** button, then touch **[GRP]** on the LCD. The “GRP” icon will appear on the display.
3. Rotate the **MULTI** knob to select the desired Memory Group.
4. Press the **F(M-LIST)** button, then touch **[MCH]** on the LCD. The “MCH” icon will appear on the display.
5. Rotate the **MULTI** knob to select the desired Memory Channel within the Selected Memory Group.

#### ADVICE:

If no channels have been assigned to a particular Memory Group, you will not have access to that Group.

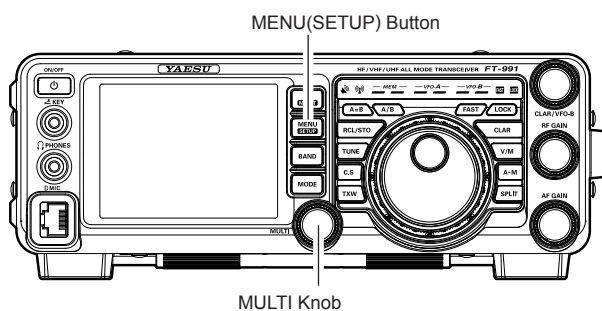

| MEMORY CHANNEL NUMBER |                   |
|-----------------------|-------------------|
| GROUP MEMORY “OFF”    | GROUP MEMORY “ON” |
| 01 ~ 19               | 1-01 ~ 1-19       |
| 20 ~ 39               | 2-01 ~ 2-20       |
| 40 ~ 59               | 3-01 ~ 3-20       |
| 60 ~ 79               | 4-01 ~ 4-20       |
| 80 ~ 99               | 5-01 ~ 5-20       |
| P-1L/1U ~ P-9L/9U     | P-1L/1U ~ P-9L/9U |
| 5M-01 ~ 5M-10         | US-1 ~ US-5       |

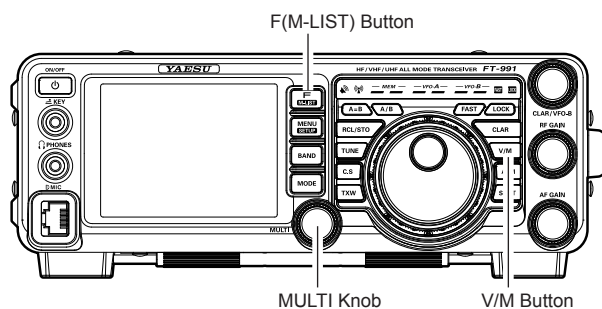

# OPERATION ON ALASKA EMERGENCY FREQUENCY: 5167.5 KHz (U.S. VERSION ONLY)

Section 97.401(d) of the regulations governing amateur radio in the United States permit emergency amateur communications on the spot frequency of 5167.5 kHz by stations in (or within 92.6 km of) the state of Alaska. This frequency is only to be used when the immediate safety of human life and/or property are threatened, and is never to be used for routine communications.

The **FT-991** includes the capability for transmission and reception on 5167.5 kHz under such emergency conditions via the Menu system. To activate this feature:

1. Press the **MENU(SETUP)** button to enter the Menu mode.
2. Rotate the **MULTI** knob to select Menu item “149 EMERGENCY FREQ TX”.
3. Touch [**SELECT**] on the LCD, then rotate the **MULTI** knob to select “ENABLE.”
4. Touch [**ENTER**] on the LCD to save the new setting.
5. Press the **MENU(SETUP)** button or [**BACK**] on the LCD to exit to normal operation. Emergency communication on this spot frequency is now possible.
6. Press the **V/M** button, as necessary, to enter the Memory mode.
7. Press the **F(M-LIST)** button, then touch [**MCH**] on the LCD.
8. Rotate the **MULTI** knob to select the emergency channel (“EMERGENCY”), which is found between channels “510” and “01”.

## NOTE:

- ❑ The receive-mode CLARIFIER functions normally while using this frequency, but variation of the transmit frequency is not possible. The full specifications of the **FT-991** are not necessarily guaranteed on this frequency, but power output and receiver sensitivity should be fully satisfactory for the purpose of emergency communication.
- ❑ If you wish to disable operation capability on the Alaska Emergency Frequency, repeat the above procedures, but set the Menu item “149 EMERGENCY FREQ TX” to “DISABLE” in step 3.
- ❑ In an emergency, note that a half-wave dipole cut for this frequency should be approximately 45’3” on each leg (90’6” total length). Emergency operation on 5167.5 kHz is shared with the Alaska-Fixed Service. This transceiver is not authorized for operation, under the FCC Part 87, for aeronautical communications.

You may scan either the VFO or the memories of the **FT-991**, and the radio will halt scanning on any frequency with a signal strong enough to open the receiver squelch.

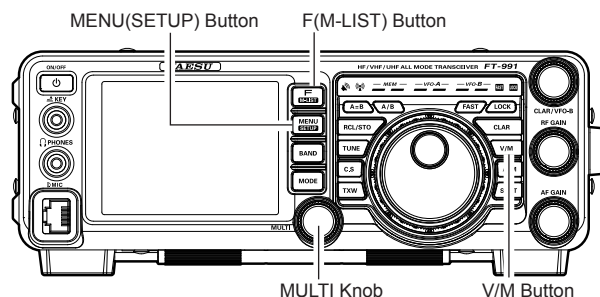



# VFO AND MEMORY SCANNING

## VFO SCANNING

1. Set the VFO-A to the frequency on which you would like to begin scanning.
2. Rotate the **RF GAIN** knob so that the background noise is just silenced.
3. Press and hold in the microphone **UP** or **DWN** button for one second to start scanning in the specified direction on the VFO frequency.
4. If the scanner halts on an incoming signal, the decimal point between the “MHz” and “kHz” digits of the frequency display will blink.

### ADVICE:

- If the incoming signal disappears, scanning will resume in about five seconds.
  - On the SSB/CW and SSB-based Data modes, the scanner will pause on a received signal, then will step across the signal very slowly, giving you time to stop the scan, if you like. In these modes on the VFO, the scanner does not stop, however.
5. To cancel scanning, press the **PTT** switch.

### ADVICE:

- If you press the microphone **PTT** switch during scanning, the scanner will halt at once. However, pressing the **PTT** switch during scanning will not cause transmission.
- You may select the manner in which the scanner resumes while it has paused on a signal, using Menu item “037 MIC SCAN RESUME”. The default “TIME” (5 sec) setting will cause the scanner to resume scanning after five seconds; you may change it, however, to resume only after the carrier has dropped out.

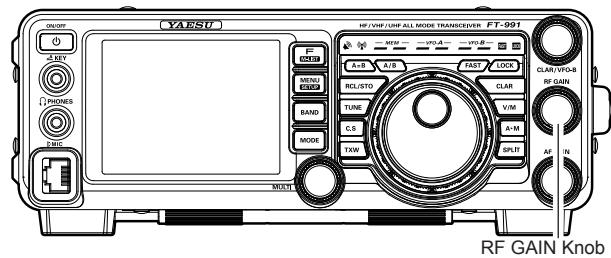

## MEMORY SCAN

1. Set the transceiver up in the “Memory” mode by pressing the **V/M** button, if necessary.
2. Rotate the **RF GAIN** knob so that the background noise is just silenced.
3. Press and hold in the microphone **UP** or **DWN** button for one second to start scanning in the specified direction.

### ADVICE:

- If the scanner halts on an incoming signal, the decimal point between the “MHz” and “kHz” digits of the frequency display will blink.
  - If the incoming signal disappears, scanning will resume in about five seconds.
4. To cancel scanning, press the **PTT** witch.

### ADVICE:

- During Memory Group operation, only the channels within the current Memory Group will be scanned.
- If the scan has paused on a signal, pressing the microphone **UP** or **DWN** button will cause scanning to resume instantly.
- If you press the microphone **PTT** switch during scanning, the scanner will halt at once. However, pressing the **PTT** switch during scanning will not cause transmission.
- You may select the manner in which the scanner resumes while it has paused on a signal, using Menu item “037 MIC SCAN RESUME”. During memory scanning, the default “TIME” (5 sec) setting will cause the scanner to resume scanning after five seconds. However, you may change this setting to resume only after the carrier has dropped out, if you like.

### QUICK POINT:

If you have no interest in scanning, and wish to prohibit the microphone **UP/DWN** buttons from initiating scanning, you may disable scanning control from the microphone using Menu item “036 MIC SCAN” (set it to “DISABLE”).

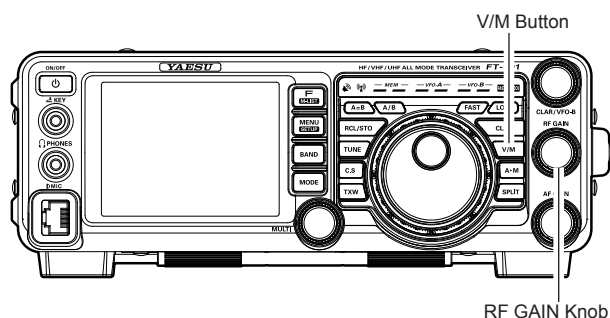

# PMS (PROGRAMMABLE MEMORY SCANNING)

To limit scanning (and manual tuning) within a particular frequency range, you can use the Programmable Memory Scanning (PMS) feature, which utilizes nine special-purpose memory pairs (“P-1L/P-1U” through “P-9L/P-9U”). The PMS feature is especially useful in helping you to observe any operating sub-band limits, which apply to your Amateur license class.

1. Store the Lower and Upper tuning/scanning limit frequencies into the memory pair “P-1L” and “P-1U”, respectively, or any other “L/U” pair of memories in the special PMS memory area. See page ## for details regarding memory storage.
2. Press the **V/M** button to enter the “Memory” mode.
3. Press the **F(M-LIST)** button, then touch **[MCH]** on the LCD. The LEDs indicating the Memory mode will illuminate.
4. Rotate the **MULTI** knob to select memory channel “P-1L” or “P-1U”.
5. Rotate the **RF GAIN** knob so that the background noise is just silenced.
6. Turn the Main Tuning Dial knob slightly (to activate memory tuning). Tuning and scanning are now limited to the range within the P-1L/P-1U limits until you press the **V/M** button to return to memory channel or VFO operation.
7. Press and hold in the microphone **UP** or **DWN** button for one second to start scanning in the specified direction.

#### ADVICE:

- If the scanner halts on an incoming signal, the decimal point between the “MHz” and “kHz” digits of the frequency display will blink.
  - If the incoming signal disappears, scanning will resume in about five seconds.
  - On the SSB/CW and SSB-based Data modes, the scanner will pause on a received signal, then will step across the signal very slowly, giving you time to stop the scan, if you like. However, in these modes on the VFO, the scanner does not stop.
  - If the scan has paused on a signal, pressing the microphone **UP** or **DWN** button will cause scanning to resume instantly.
8. If you rotate the Main Tuning Dial knob in the opposite direction from the current scanning direction (in other words, you rotate the dial to the left when scanning toward a higher frequency), the direction of the scan will reverse.
  9. If you press the microphone **PTT** switch during scanning, the scanner will halt at once. Pressing the **PTT** switch *during scanning* will not cause transmission.

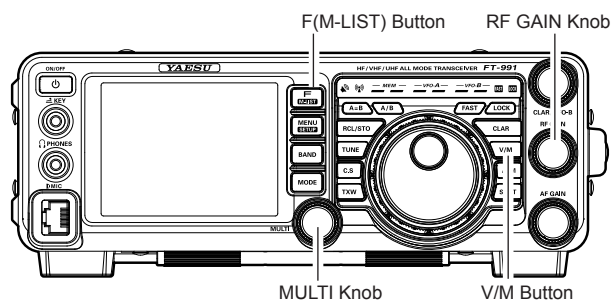

# RTTY (RADIO TELETYPE) OPERATION

## EXAMPLE OF CONNECTING RTTY COMMUNICATIONS DEVICE

Connect the RTTY communications TU (Terminal Unit) to the rear panel RTTY/PKT terminal. Be sure to read the instructions manual of the device to connect when connecting.

See page ## for details on the connections and settings to use the optional USB Interface Unit “SCU-17”.

### ADVICE:

You can adjust RTTY data output level using Menu item “099 RTTY OUT LEVEL”.

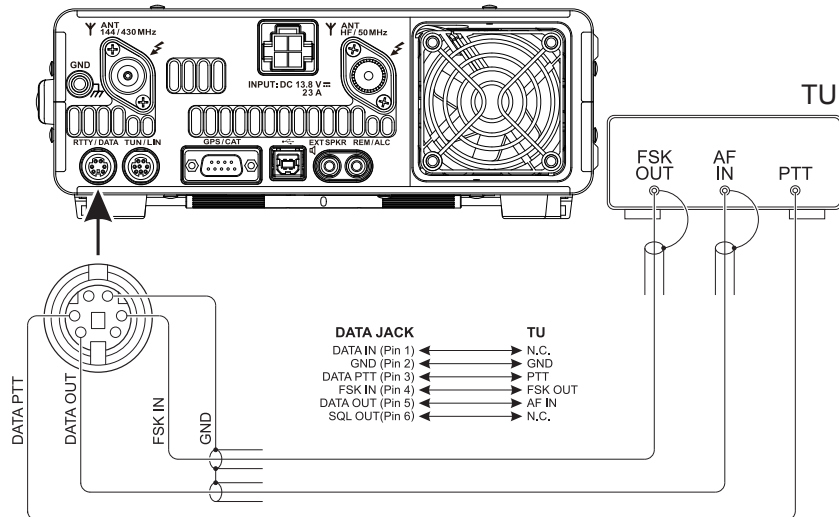

# DATA (PSK) OPERATION

## EXAMPLE OF DATA COMMUNICATIONS DEVICE

You can use commercial and free computer software for PSK data communications. See the illustration below for connection to your computer.

Be sure to read the instruction manual of the device to be connected to the radio and computer.

See page ## for details on the connections and settings to use the optional USB Interface Unit “SCU-17”.

### ADVICE:

❑ You can set the data output level for data communications (PSK31, SSTV, etc.) using Menu item “075 DATA OUT LEVEL”.

❑ You can set VOX DELAY in VOX operation for data communications (PSK31, SSTV, etc.) using Menu item “147 DATA VOX DELAY”. You can also set data input VOX gain using Menu item “146 DATA VOX GAIN”.

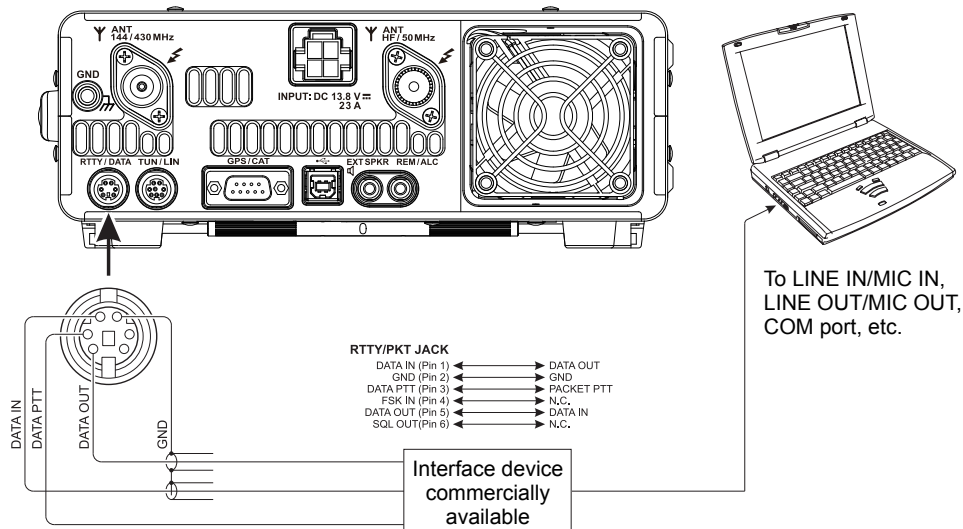

The Menu system of the **FT-991** provides extensive customization capability, so you can set up your transceiver just the way you want to operate it. The Menu items are grouped by general utilization category, and are numbered from “001 AGC” to “149 E/D PSK”.

## Using the Menu

1. Press the **MENU(SETUP)** button to engage the Menu mode.  
The display will show the Menu Number, the Menu Group Name and the Menu Item.
2. Rotate the **MULTI** knob to select the Menu item you wish to modify.
3. Touch [**SELECT**] on the LCD, then rotate the **MULTI** knob to change the current setting of the selected Menu item.

### ADVICE:

- Touch [**BACK**] on the LCD to cancel the setting.
4. When you have finished making your adjustments, touch [**ENTER**] on the LCD to save the new setting, then press the **MENU(SETUP)** button or touch [**BACK**] on the LCD to exit to normal operation.

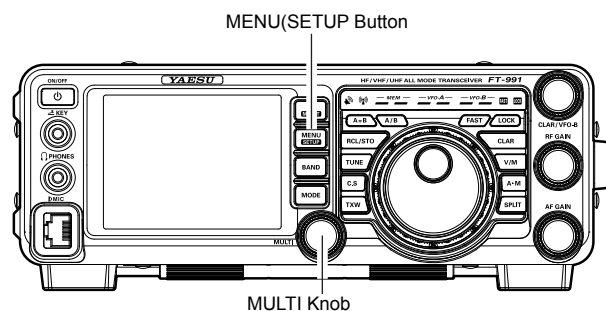

# MENU MODE

| Group   | No. | Menu Function     | Available Settings                              | Default Value |
|---------|-----|-------------------|-------------------------------------------------|---------------|
| AGC     | 001 | FAST DELAY        | 20 ~ 4000 (20msec/step)                         | 300msec       |
| AGC     | 002 | MID DELAY         | 20 ~ 4000 (20msec/step)                         | 700msec       |
| AGC     | 003 | SLOW DELAY        | 20 ~ 4000 (20msec/step)                         | 3000msec      |
| DISPLAY | 004 | MY CALL TIME      | OFF ~ 5sec                                      | 1sec          |
| DISPLAY | 005 | DISPLAY COLOR     | BLUE/GRAY/GREEN/ORANGE/PURPLE/RED/<br>SKY BLUE/ | BLUE          |
| DISPLAY | 006 | DIMMER LED        | 1/2                                             | 2             |
| DISPLAY | 007 | DIMMER TFT        | 0 ~ 15                                          | 8             |
| DISPLAY | 008 | BAR MTR PEAK HOLD | OFF/0.5/1.0/2.0 (sec)                           | OFF           |
| DVS     | 009 | RX OUT LEVEL      | 0 ~ 100                                         | 50            |
| DVS     | 010 | TX OUT LEVEL      | 0 ~ 100                                         | 50            |
| KEYER   | 011 | KEYER TYPE        | OFF/BUG/ELEKEY-A/ELEKEY-B/ELEKEY-Y/<br>ACS      | ELEKEY-B      |
| KEYER   | 012 | CW KEYER          | NOR/REV                                         | NOR           |
| KEYER   | 013 | CW WEIGHT         | 2.5 ~ 4.5                                       | 3.0           |
| KEYER   | 014 | BEACON TIME       | OFF/1 ~ 240sec/270 ~ 690sec                     | OFF           |
| KEYER   | 015 | NUMBER STYLE      | 1290/AUNO/AUNT/A2NO/A2NT/12NO/12NT              | 1290          |
| KEYER   | 016 | CONTEST NUMBER    | 0 ~ 9999                                        | 1             |
| KEYER   | 017 | CW MEMORY 1       | TEXT/MESSAGE                                    | TEXT          |
| KEYER   | 018 | CW MEMORY 2       | TEXT/MESSAGE                                    | TEXT          |
| KEYER   | 019 | CW MEMORY 3       | TEXT/MESSAGE                                    | TEXT          |
| KEYER   | 020 | CW MEMORY 4       | TEXT/MESSAGE                                    | TEXT          |
| KEYER   | 021 | CW MEMORY 5       | TEXT/MESSAGE                                    | TEXT          |
| GENERAL | 022 | NB WIDTH          | 1/3/10msec                                      | 3msec         |
| GENERAL | 023 | NB REJECTION      | 10/30/50dB                                      | 30dB          |
| GENERAL | 024 | NB LEVEL          | 0 ~ 100                                         | 50dB          |
| GENERAL | 025 | BEEP LEVEL        | 0 ~ 100                                         | 50            |
| GENERAL | 026 | TIME ZONE         | -12:00 ~ 0:00 ~ +14:00                          | 0:00          |
| GENERAL | 027 | GPS/232C SELECT   | GPS/RS232C                                      | GPS           |
| GENERAL | 028 | 232C RATE         | 4800/9600/19200/38400 (bps)                     | 4800bps       |
| GENERAL | 029 | 232C TOT          | 10/100/1000/3000 (msec)                         | 10msec        |
| GENERAL | 030 | CAT RATE          | 4800/9600/19200/38400 (bps)                     | 4800bps       |
| GENERAL | 031 | CAT TOT           | 10/100/1000/3000 (msec)                         | 10msec        |
| GENERAL | 032 | CAT RTS           | ENABLE/DISABLE                                  | ENABLE        |
| GENERAL | 033 | MEM GROUP         | ENABLE/DISABLE                                  | DISABLE       |
| GENERAL | 034 | QUICK SPLIT FREQ  | -20 ~ +20kHz                                    | 5kHz          |
| GENERAL | 035 | TX TOT            | OFF/1 ~ 30 (min)                                | OFF           |
| GENERAL | 036 | MIC SCAN          | ENABLE/DISABLE                                  | ENABLE        |
| GENERAL | 037 | MIC SCAN RESUME   | PAUSE/TIME                                      | TIME          |
| GENERAL | 038 | FREQ ADJ          | -25 ~ 0 ~ 25                                    | 0             |
| GENERAL | 039 | CLAR SELECT       | RX/TX/TRX                                       |               |
| MODE-AM | 040 | AM LCUT FREQ      | OFF/100Hz ~ 1000Hz (50Hz/step)                  | OFF           |
| MODE-AM | 041 | AM LCUT SLOPE     | 6dB/oct / 18dB/oct                              | 6dB/oct       |
| MODE-AM | 042 | AM HCUT FREQ      | 700Hz ~ 4000Hz (50Hz/step) / OFF                | OFF           |
| MODE-AM | 043 | AM HCUT SLOPE     | 6dB/oct / 18dB/oct                              | 6dB/oct       |
| MODE-AM | 044 | AM MIC SEL        | MIC/REAR                                        | MIC           |
| MODE-AM | 045 | AM MIC GAIN       | MCVR/0 ~ 100                                    | 30            |
| MODE-AM | 046 | AM OUT LEVEL      | 0 ~ 100                                         | 50            |
|         | 047 | REAR PTT SELECT   | DAKY/RTS/DTR                                    | DAKY          |
|         | 048 | REAR PORT SELECT  | DATA/USB                                        | DATA          |
|         | 049 | AM DATA GAIN      | 0 ~ 100                                         | 50            |
| MODE-CW | 050 | CW LCUT FREQ      | OFF/100Hz ~ 1000Hz(50Hz/step)                   | 250Hz         |
| MODE-CW | 051 | CW LCUT SLOPE     | 6dB/oct / 18dB/oct                              | 18dB/oct      |

| Group     | No. | Menu Function     | Available Settings               | Default Value |
|-----------|-----|-------------------|----------------------------------|---------------|
| MODE-CW   | 052 | CW HCUT FREQ      | 700Hz ~ 4000Hz(50Hz/step)        | 1200Hz        |
| MODE-CW   | 053 | CW HCUT SLOPE     | 6dB/oct / 18dB/oct               | 18dB/oct      |
| MODE-CW   | 054 | CW OUT LEVEL      | 0 ~ 100                          | 50            |
| MODE-CW   | 055 | CW AUTO MODE      | OFF/50M/ON                       | OFF           |
| MODE-CW   | 056 | CW BFO            | USB/LSB/AUTO                     | USB           |
| MODE-CW   | 057 | CW BK-IN          | SEMI/FULL                        | SEMI          |
| MODE-CW   | 058 | CW BK-IN DELAY    | 30 ~ 3000 (msec)                 | 200msec       |
| MODE-CW   | 059 | CW WAVE SHAPE     | 1/2/4/6 (msec)                   | 4msec         |
| MODE-CW   | 060 | CW FREQ DISPLAY   | DIRECT FREQ/PITCH OFFSE          | PITCH OFFSE   |
| MODE-CW   | 061 | PC KEYING         | OFF/DAKY/RTS/DTR                 | OFF           |
| MODE-CW   | 062 | QSK               | 15/20/25/30(msec)                | 15msec        |
| MODE-DATA | 063 | DATA MODE         | PSK/OTHERS                       | PSK           |
| MODE-DATA | 064 | PSK TONE          | 1000/1500/2000(Hz)               | 1000Hz        |
| MODE-DATA | 065 | OTHER DISP (SSB)  | -3000 ~ 0 ~ +3000(10Hz/step)     | 0Hz           |
| MODE-DATA | 066 | OTHER SHIFT (SSB) | -3000 ~ 0 ~ +3000(10Hz/step)     | 0Hz           |
| MODE-DATA | 067 | DATA LCUT FREQ    | OFF/100 ~ 1000(Hz)(50Hz/step)    | 300Hz         |
| MODE-DATA | 068 | DATA LCUT SLOPE   | 6dB/oct / 18dB/oct               | 18dB/oct      |
| MODE-DATA | 069 | DATA HCUT FREQ    | 700 ~ 4000(Hz)(50Hz/step)/OFF    | 3000Hz        |
| MODE-DATA | 070 | DATA HCUT SLOPE   | 6dB/oct / 18dB/oc                | 18dB/oct      |
| MODE-DATA | 071 | DATA IN SELECT    | REAR/MIC                         | REAR          |
| MODE-DATA | 072 | DATA MIC GAIN     | 0 ~ 100                          | 50            |
| MODE-DATA | 073 | REAR PTT SELECT   | DAKY/RTS/DTR                     | DAKY          |
| MODE-DATA | 074 | REAR PORT SELECT  | DATA/USB                         | DATA          |
| MODE-DATA | 075 | DATA OUT LEVEL    | 0 ~ 100                          | 50            |
| MODE-FM   | 076 | FM MIC SEL        | MIC/REAR                         | MIC           |
| MODE-FM   | 077 | FM MIC GAIN       | MCVR/0 ~ 100                     | 30            |
| MODE-FM   | 078 | FM OUT LEVEL      | 0 ~ 100                          | 50            |
| MODE-FM   | 079 | REAR PTT SELECT   | DAKY/RTS/DTR                     | DARY          |
| MODE-FM   | 080 | REAR PORT SELECT  | DATA/USB                         | DATA          |
| MODE-FM   | 081 | FM PKT GAIN       | 0 ~ 100                          | 50            |
| MODE-FM   | 082 | FM PKT MODE       | 1200/9600                        | 1200          |
| MODE-FM   | 083 | RPT SHIFT 28MHz   | 0 ~ 1000kHz (10kHz/step)         | 100kHz        |
| MODE-FM   | 084 | RPT SHIFT 50MHz   | 0 ~ 4000kHz (10kHz/step)         | 1000kHz       |
| MODE-FM   | 085 | RPT SHIFT 144MHz  | 0 ~ 4000kHz (10kHz/step)         | 600kHz        |
| MODE-FM   | 086 | RPT SHIFT 430MHz  | 0 ~ 9990kHz (10kHz/step)         | 5000kHz       |
| MODE-FM   | 087 | ARS 144MHz        | OFF/ON                           | ON            |
| MODE-FM   | 088 | ARS 430MHz        | OFF/ON                           | ON            |
|           | 089 | DCS POLARITY      | Tn-Rn/Tn-Riv/Tiv-Rn/Tin-Riv      | Tn-Rn         |
|           | 090 | AMS TX MODE       | AUTO/DN/VW/ANALOG                | AUTO          |
|           | 091 | RADIO ID          |                                  | *****         |
| MODE-RTTY | 092 | RTTY LCUT FREQ    | OFF/100Hz ~ 1000Hz (50Hz/step)   | 300Hz         |
| MODE-RTTY | 093 | RTTY LCUT SLOPE   | 6dB/oct / 18dB/oct               | 18dB/oct      |
| MODE-RTTY | 094 | RTTY HCUT FREQ    | 700Hz ~ 4000Hz (50Hz/step) / OFF | 3000Hz        |
| MODE-RTTY | 095 | RTTY HCUT SLOPE   | 6dB/oct / 18dB/oct               | 18dB/oct      |
| MODE-RTTY | 096 | RTTY SHIFT PORT   | SHIFT/DTR/RTS                    | SHIFT         |
| MODE-RTTY | 097 | POLARITY-R        | NOR/REV                          | NOR           |
| MODE-RTTY | 098 | POLARITY-T        | NOR/REV                          | NOR           |
| MODE-RTTY | 099 | RTTY OUT LEVEL    | 0 ~ 100                          | 50            |
| MODE-RTTY | 100 | RTTY SHIFT        | 170/200/425/850 (Hz)             | 170Hz         |
| MODE-RTTY | 101 | RTTY MARK FREQ    | 1275/2125 (Hz)                   | 2125Hz        |
| MODE-SSB  | 102 | SSB LCUT FREQ     | OFF/100Hz ~ 1000Hz (50Hz/step)   | 100Hz         |
| MODE-SSB  | 103 | SSB LCUT SLOPE    | 6dB/oct / 18dB/oct               | 6dB/oct       |
| MODE-SSB  | 104 | SSB HCUT FREQ     | 700Hz ~ 4000Hz (50Hz/step) / OFF | 3000Hz        |



# MENU MODE

| Group    | No. | Menu Function      | Available Settings                           | Default Value |
|----------|-----|--------------------|----------------------------------------------|---------------|
| MODE-SSB | 105 | SSB HCUT SLOPE     | 6dB/oct / 18dB/oct                           | 6dB/oct       |
| MODE-SSB | 106 | SSB MIC SELECT     | MIC/REAR                                     | MIC           |
| MODE-SSB | 107 | SSB OUT LEVEL      | 0 ~ 100                                      | 50            |
|          | 108 | REAR PTT SELECT    | DAKY                                         | DAKY          |
|          | 109 | REAR PORT SELECT   | DATA/USB                                     | DATA          |
| MODE-SSB | 110 | SSB TX BPF         | 100-3000/100-2900/200-2800/300-2700/400-2600 | 300-2700      |
| RX-DSP   | 111 | APF WIDTH          | NARROW/MEDIUM/WIDE                           | MEDIUM        |
| RX-DSP   | 112 | CONTOUR LEVE       | -40 ~ 0 ~ 20                                 | -15           |
| RX-DSP   | 113 | CONTOUR WIDTH      | 1 ~ 11                                       | 10            |
| RX-DSP   | 114 | IF NOTCH WIDTH     | NARROW/WIDE                                  | WIDE          |
| AF-SCOPE | 115 | DISPLAY MODE       | SPECTRUM/WATER FALL                          | SPECTRUM      |
|          | 116 | START CYCLE        | OFF/3/5/10 (sec)                             | OFF           |
|          | 117 | START DIAL SPEED   | 0.25kHz/0.5kHz/1kHz/2kHz/4kHz (sec)          | 1kHz/sec      |
|          | 118 | SPAN FREQ          | 50/100/200/500/1000 (kHz)                    | 100kHz        |
| TX AUDIO | 119 | PRMTRC EQ1 FREQ    | OFF/100 ~ 700 (100/step)                     | OFF           |
| TX AUDIO | 120 | PRMTRC EQ1 LEVEL   | -20 ~ 0 ~ +10                                | 5             |
| TX AUDIO | 121 | PRMTRC EQ1 BWTH    | 1 ~ 10                                       | 10            |
| TX AUDIO | 122 | PRMTRC EQ2 FREQ    | OFF/700 ~ 1500 (100/step)                    | OFF           |
| TX AUDIO | 123 | PRMTRC EQ2 LEVEL   | -20 ~ 0 ~ +10                                | 5             |
| TX AUDIO | 124 | PRMTRC EQ2 BWTH    | 1 ~ 10                                       | 10            |
| TX AUDIO | 125 | PRMTRC EQ3 FREQ    | OFF/1500 ~ 3200 (100/step)                   | OFF           |
| TX AUDIO | 126 | PRMTRC EQ3 LEVEL   | -20 ~ 0 ~ +10                                | 5             |
| TX AUDIO | 127 | PRMTRC EQ3 BWTH    | 1 ~ 10                                       | 10            |
| TX AUDIO | 128 | P-PRMTRC EQ1 FREQ  | OFF/100 ~ 700 (100/step)                     | 200           |
| TX AUDIO | 129 | P-PRMTRC EQ1 LEVEL | -20 ~ 0 ~ 10                                 | 0             |
| TX AUDIO | 130 | P-PRMTRC EQ1 BWTH  | 1 ~ 10                                       | 2             |
| TX AUDIO | 131 | P-PRMTRC EQ2 FREQ  | OFF/700 ~ 1500 (100/step)                    | 800           |
| TX AUDIO | 132 | P-PRMTRC EQ2 LEVEL | -20 ~ 0 ~ 10                                 | 0             |
| TX AUDIO | 133 | P-PRMTRC EQ2 BWTH  | 1 ~ 10                                       | 1             |
| TX AUDIO | 134 | P-PRMTRC EQ3 FREQ  | OFF/1500 ~ 3200 (100/step)                   | 2100          |
| TX AUDIO | 135 | P-PRMTRC EQ3 LEVEL | -20 ~ 0 ~ 10                                 | 0             |
| TX AUDIO | 136 | P-PRMTRC EQ3 BWTH  | 1 ~ 10                                       | 1             |
| TX GNRL  | 137 | HF TX MAX POWER    | 5 ~ 100                                      | 100           |
| TX GNRL  | 138 | 50M TX MAX POWER   | 0 ~ 100                                      | 100           |
| TX GNRL  | 139 | 144M TX MAX POWER  | 0 ~ 50                                       | 50            |
| TX GNRL  | 140 | 430M TX MAX POWER  | 0 ~ 50                                       | 50            |
| TX GNRL  | 141 | TUNER SELECT       | OFF/INTERNAL/EXTERNAL/ATAS/LAMP              | INTERNAL      |
| TX GNRL  | 142 | VOX SELECT         | MIC/DATA                                     | MIC           |
| TX GNRL  | 143 | VOX GAIN           | 0 ~ 100                                      | 50            |
| TX GNRL  | 144 | VOX DELAY          | 30 ~ 3000 (msec)                             | 500msec       |
| TX GNRL  | 145 | ANTI VOX GAIN      | 0 ~ 100                                      | 50            |
| TX GNRL  | 146 | DATA VOX GAIN      | 0 ~ 100                                      | 50            |
| TX GNRL  | 147 | DATA VOX DELAY     | 30 ~ 3000 (msec)                             | 100msec       |
| TX GNRL  | 148 | ANTI DVOX GAIN     | 0 ~ 100                                      | 0             |
| TX GNRL  | 149 | EMERGENCY FREQ TX  | DISABLE/ENABLE                               | DISABLE       |

## General

|                                     |                                                                                                                                                                               |
|-------------------------------------|-------------------------------------------------------------------------------------------------------------------------------------------------------------------------------|
| <b>Rx Frequency Range:</b>          | 30 kHz - 55.999995 MHz<br>118 MHz - 163.999995 MHz<br>420 MHz - 469.999995 MHz                                                                                                |
| <b>Tx Frequency Ranges:</b>         | 1.8 MHz - 430 MHz (Amateur bands only)                                                                                                                                        |
| <b>Frequency Stability:</b>         | ±0.5 ppm (after 1 minute @+14 °F to +140 °F [-10 °C to +60 °C])                                                                                                               |
| <b>Operating Temperature Range:</b> | +14 °F to +122 °F (-10 °C to +50 °C)                                                                                                                                          |
| <b>Emission Modes:</b>              | A1A, A3E, J3E, F3E, F7W, F1B, F1D, F2D, G1B                                                                                                                                   |
| <b>Frequency Steps:</b>             | 5/10 Hz (SSB, CW), 50/100 Hz (AM, FM)                                                                                                                                         |
| <b>Antenna Impedance:</b>           | 50 Ohms, unbalanced<br>16.7 - 150 Ohms, unbalanced (1.8 MHz - 29.7 MHz)<br>25 - 100 Ohms, unbalanced (50 MHz - 54 MHz)<br>(Tuner ON, 1.8 MHz - 50 MHz Amateur bands, TX only) |
| <b>Power Consumption (Approx.):</b> | Rx (no signal) 1.8 A<br>Rx (signal present) 2.2 A<br>Tx (HF/50 MHz, 100 W) 22 A, (144/430 MHz, 50 W) 15 A                                                                     |
| <b>Supply Voltage:</b>              | DC 13.8 V ± 15 % (Negative Ground)                                                                                                                                            |
| <b>Dimensions (WxHxD):</b>          | 9.01" x 3.15" x 9.96" (229 x 80 x 253 mm)                                                                                                                                     |
| <b>Weight (Approx.):</b>            | 9.46 lbs (4.3 kg)                                                                                                                                                             |

## Transmitter

|                                        |                                                                                                                 |
|----------------------------------------|-----------------------------------------------------------------------------------------------------------------|
| <b>Power Output:</b>                   | HF/50 MHz: 5 - 100 watts (2.5 - 25 watts AM carrier)<br>144/430 MHz: 5 - 50 watts (2.5 - 12.5 watts AM carrier) |
| <b>Modulation Types:</b>               | J3E: Balanced,<br>A3E: Low-Level (Early Stage),<br>F3E: Variable Reactance<br>F7W: 4FSK (C4FM)                  |
| <b>Maximum FM Deviation:</b>           | ±5.0 kHz/±2.5 kHz                                                                                               |
| <b>Harmonic Radiation:</b>             | Better than -50 dB (below 30 MHz)<br>Better than -60 dB (above 30 MHz)                                          |
| <b>SSB Carrier Suppression:</b>        | At least 50 dB below peak output                                                                                |
| <b>Undesired Sideband Suppression:</b> | At least 50 dB below peak output                                                                                |
| <b>Bandwidth:</b>                      | 3 kHz (LSB/USB), 500 Hz (CW), 6 kHz (AM), 16 kHz (FM)                                                           |
| <b>Audio Response (SSB):</b>           | Not more than -6 dB from 300 to 2700 Hz                                                                         |
| <b>Microphone Impedance:</b>           | 600 Ohms (200 to 10 kOhms)                                                                                      |

# SPECIFICATIONS

## Receiver

|                                     |                                                                                                                                                                                                                                                                                                                                                                                                                                                                                                                                                                                                                                                                                       |                                        |
|-------------------------------------|---------------------------------------------------------------------------------------------------------------------------------------------------------------------------------------------------------------------------------------------------------------------------------------------------------------------------------------------------------------------------------------------------------------------------------------------------------------------------------------------------------------------------------------------------------------------------------------------------------------------------------------------------------------------------------------|----------------------------------------|
| <b>Circuit Type:</b>                | SSB/CW/AM: Triple-conversion Superheterodyne<br>FM: Double-conversion Superheterodyne                                                                                                                                                                                                                                                                                                                                                                                                                                                                                                                                                                                                 |                                        |
| <b>Intermediate Frequencies:</b>    | 69.450 MHz<br>9.000 MHz (SSB, CW, AM)<br>24 kHz (SSB, CW, AM)<br>450 kHz (FM)                                                                                                                                                                                                                                                                                                                                                                                                                                                                                                                                                                                                         |                                        |
| <b>Sensitivity:</b>                 | SSB/CW (10 dB S+N/N)<br>0.158 $\mu$ V (1.8 - 30 MHz) (RF AMP 2 "ON")<br>0.125 $\mu$ V (50 - 54 MHz) (RF AMP 2 "ON")<br>0.125 $\mu$ V (144 - 146 MHz) (RF AMP 2 "ON")<br>0.125 $\mu$ V (430 - 440 MHz) (RF AMP 2 "ON")<br>AM (10 dB S+N/N, 30 % modulation @400 Hz)<br>28 $\mu$ V (0.1 - 1.8 MHz) (RF AMP 2 "ON")<br>2 $\mu$ V (1.8 - 30 MHz) (RF AMP 2 "ON")<br>1 $\mu$ V (50 - 54 MHz) (RF AMP 2 "ON")<br>FM (12 dB SINAD)<br>0.5 $\mu$ V (1.8 - 30 MHz) (RF AMP 2 "ON")<br>0.25 $\mu$ V (50 - 54 MHz) (RF AMP 2 "ON")<br>0.18 $\mu$ V (144 - 146 MHz) (RF AMP 2 "ON")<br>0.18 $\mu$ V (430 - 440 MHz) (RF AMP 2 "ON")<br>There is no specification for frequency ranges not listed. |                                        |
| <b>Selectivity (WIDTH: Center):</b> | Mode                                                                                                                                                                                                                                                                                                                                                                                                                                                                                                                                                                                                                                                                                  | -6 dB                      -60 dB      |
|                                     | SSB/CW (Width=2.4 kHz)                                                                                                                                                                                                                                                                                                                                                                                                                                                                                                                                                                                                                                                                | 2.4 kHz or better      3.6 kHz or less |
|                                     | CW-N (Width =500 Hz)                                                                                                                                                                                                                                                                                                                                                                                                                                                                                                                                                                                                                                                                  | 0.5 kHz or better      750 Hz or less  |
|                                     | AM                                                                                                                                                                                                                                                                                                                                                                                                                                                                                                                                                                                                                                                                                    | 6 kHz or better        15 kHz or less  |
|                                     | FM                                                                                                                                                                                                                                                                                                                                                                                                                                                                                                                                                                                                                                                                                    | 12 kHz or better       30 kHz or less  |
|                                     | FM-N                                                                                                                                                                                                                                                                                                                                                                                                                                                                                                                                                                                                                                                                                  | 9 kHz or better        25 kHz or less  |
| <b>Image Rejection:</b>             | 70 dB or better (1.8 MHz - 50 MHz Amateur bands)<br>60 dB or better (144/430 MHz Amateur band)                                                                                                                                                                                                                                                                                                                                                                                                                                                                                                                                                                                        |                                        |
| <b>Maximum Audio Output:</b>        | 2.5 W into 4 Ohms with 10% THD                                                                                                                                                                                                                                                                                                                                                                                                                                                                                                                                                                                                                                                        |                                        |
| <b>Audio Output Impedance:</b>      | 4 to 16 Ohms (8 Ohms: nominal)                                                                                                                                                                                                                                                                                                                                                                                                                                                                                                                                                                                                                                                        |                                        |
| <b>Conducted Radiation:</b>         | Less than 4000 uuW                                                                                                                                                                                                                                                                                                                                                                                                                                                                                                                                                                                                                                                                    |                                        |

*Specifications are subject to change, in the interest of technical improvement, without notice or obligation, and are guaranteed only within the amateur bands.*

This equipment has been tested and found to comply with the limits for a Class B digital device, pursuant to Part 15 of the FCC Rules. These limits are designed to provide reasonable protection against harmful interference in a residential installation. This equipment generates, uses and can radiate radio frequency energy and, if not installed and used in accordance with the instructions, may cause harmful interference to radio communications. However, there is no guarantee that interference will not occur in a particular installation.

If this equipment does cause harmful interference to radio or television reception, which can be determined by turning the equipment off and on, the user is encouraged to try to correct the interference by one or more of the following measures:

- Increase the separation between the equipment and receiver.
- Connect the equipment into an outlet on a circuit different from that to which the receiver is connected.
- Consult the dealer or an experienced radio/TV technician for help.

1. Changes or modifications to this device not expressly approved by YAESU MUSEN could void the user's authorization to operate this device.
2. This device complies with part 15 of the FCC Rules. Operation is subject to the following two conditions; (1) this device may not cause harmful interference, and (2) this device must accept any interference including interference that may cause undesired operation.
3. The scanning receiver in this equipment is incapable of tuning, or readily being altered, by the User to operate within the frequency bands allocated to the Domestic public Cellular Telecommunications Service in Part 22.

This device complies with Industry Canada licence-exempt RSS standard(s). Operation is subject to the following two conditions: (1) this device may not cause interference, and (2) this device must accept any interference, including interference that may cause undesired operation of the device.

Le présent appareil est conforme aux CNR d'Industrie Canada applicables aux appareils radio exempts de licence. L'exploitation est autorisée aux deux conditions suivantes : (1) l'appareil ne doit pas produire de brouillage, et (2) l'utilisateur de l'appareil doit accepter tout brouillage radioélectrique subi, même si le brouillage est susceptible d'en compromettre le fonctionnement.

#### DECLARATION BY MANUFACTURER

The scanner receiver is not a digital scanner and is incapable of being converted or modified into a digital scanner receiver by any user.

**WARNING: MODIFICATION OF THIS DEVICE TO RECEIVE CELLULAR RADIOTELEPHONE SERVICE SIGNALS IS PROHIBITED UNDER FCC RULES AND FEDERAL LAW.**

CAN ICES-3 (B) / NMB-3 (B)

***YAESU***  
***The radio***

Copyright 2014  
YAESU MUSEN CO., LTD.  
All rights reserved

No portion of this manual  
may be reproduced without  
the permission of  
YAESU MUSEN CO., LTD.

Printed in Japan